

Vol. 4, No. 2

JUNE 1996

FULCRUM

Copyright 1996

*The Science Journal of
The University Of Science And Philosophy*

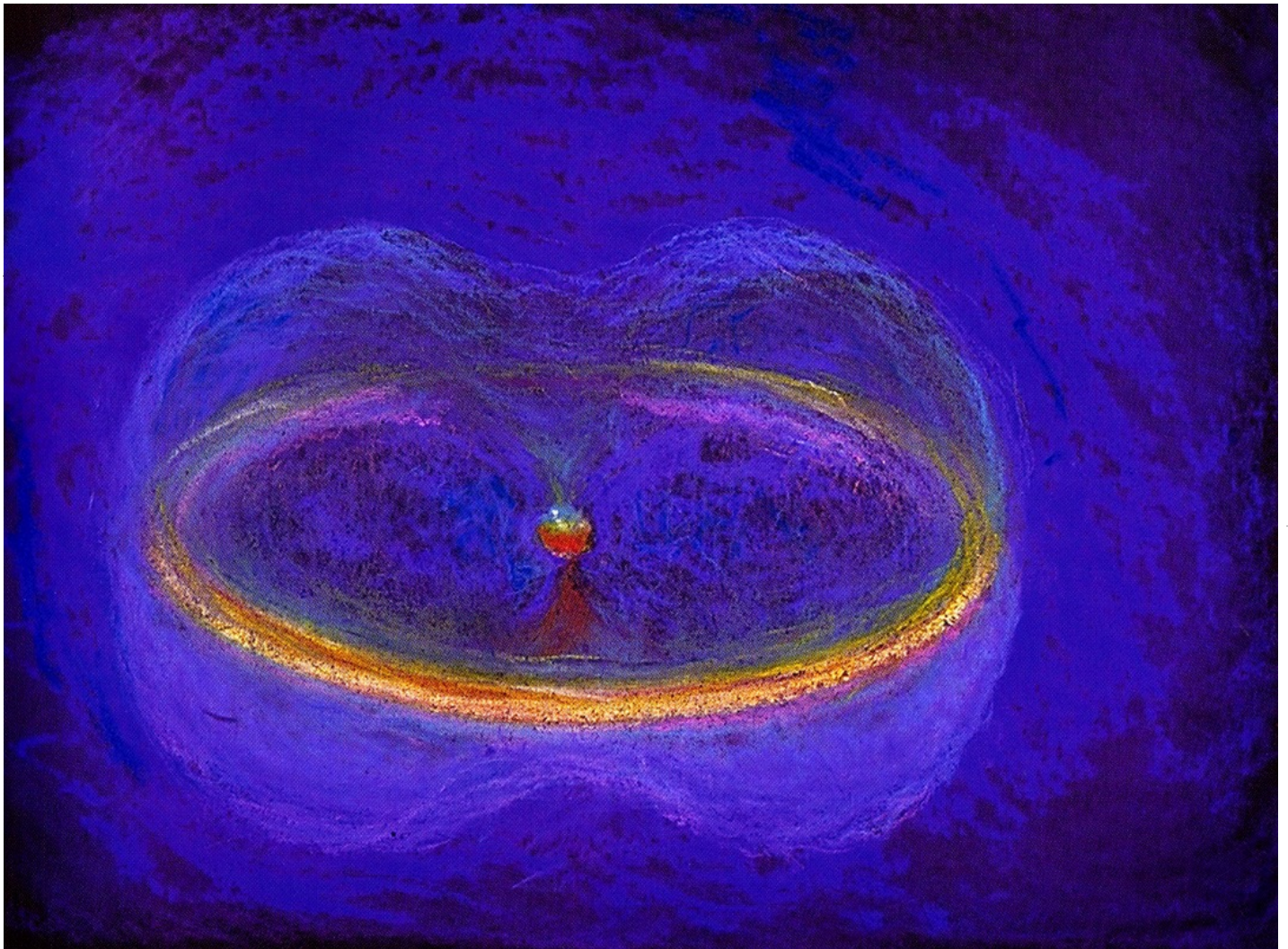

FULCRUM

Volume 4, Number 2

June 1996

Fulcrum focuses on the science of creation as revealed to Walter Russell. Dr. Russell, artist/philosopher/illuminate, spent 35 years describing the Creator's multidimensional creation process to scientists and lay persons. Known as the Russell Cosmogony and published in several different written editions, the concepts revealed to Dr. Russell during his 39 day illumination in 1921 describe our multidimensional Universe as an extension of the One substance of God. More specifically all matter is described as Light. The Light of Thinking Mind spirally winds in centripetal vortex motion the One substance into the many forms we witness. Mind also unwinds through centrifugal vortex motion all manifest form into the formless zero from which it appeared.

The Russell Cosmogony can be found in its most mature form in *A New Concept Of The Universe, Atomic Suicide?, The Home Study Course, and The Secret Of Light*. His earlier descriptions can be found in *The Universal One* and *The Russell Genero - Radiative Concept*.

Fulcrum is now a tertiary and greatly expanded forum in which scholars and students can interact to exchange insights and perspectives on the interpretation and application of the principles of the Russell Cosmogony. *Fulcrum* is engaged in extending the understanding of the Russell Cosmogony as it applies to all of our civilization's institutions that this teaching might continue to grow and act as a mighty seed to assist the birth of a peaceful and sustainable culture.

As the editor I intend to publish articles by creative thinkers, artists and inventors that can help demonstrate the Russell's principles and make a difference in the direction of our world today- right now! Understanding the whole cycle vision of Universe as given by the Russell's and application of our understanding by students and scholars is essential for this work to complete its mission for the world. Without this demonstration humanity will continue on in its present beliefs in a Universe dying a heat death, where energy only runs downhill, where there is not enough life support let alone luxury or excess abundance to go around, where God is vengeful and thus so are we, where health is found in magic bullets, and everything is moving to greater and greater disorder- where entropy reigns supreme and unchallenged.

Our present science and technology, economic, social,

psychological, medical, philosophical, political and religious systems are patterned on entropic beliefs and foster entropic thinking and actions.

I will publish:

1) A dialogue with you on the Russell Cosmogony and literature. I invite questions from readers which may be published in each issue and answers given by you the readers or by me that will follow in the next issue. The responses may or may not be definitive. I intend to be clear, although clarity may take time to unfold. Our shared insights may or may not reach similar conclusions. My intent is that by sharing questions and answers, by sharing our perspectives and insights we will stimulate each others thinking and teach each other in the process. I invite you to participate. Have no fear, ask questions and give responses no matter what level of understanding and experience with this work you perceive yourself as having. We all come from, have access to and have our present being in the same source, the same source and being that the Russell's had.

2) Research and articles relevant to the Russell Cosmogony or that have meaning for humanity's need at this moment. What are your insights from this work? Do you know of other scientists, illuminates, or common people that have published works that have meaning for our common needs now? How do you see our institutions (science, art, religion, commerce, agriculture, education, medicine, and our human relations) from your understanding of the Russell work? I am eager to review your treatments and demonstrations of the Russell concepts for possible publication.

3) Articles on current or past experiments in the field of science and technology especially as it relates to non-polluting sustainable energy production and transportation, agriculture, medicine, economics, education, art, parapsychology, psychology, religion and metaphysics.

4) Articles on any application of the Russell work that might make a positive difference in humanity's future.

5) Patent papers on free energy inventions and articles about them.

I am pleased to present this issue of *Fulcrum* to you and look forward to your input and feedback.

Dr. Timothy A Binder, Editor

Table of Contents

Dialogue

Questions for next issue	pg	1
Responses to previous questions	pgs	1-3

Letters to the Editor.	pgs	3-5
-----------------------------	-----	-----

Featured articles

<i>Causes and Remedies of Oxygen/Ozone Depletion</i>	pgs	5-10
by Dr. Timothy A Binder		
<i>The Dangers of Computer Monitor/TV Radiation Emissions and the Protective Measures Available</i> by Sandra Lee Reamer B.A. & M.F.A. Candidate, Pratt Institute, NYC, NY and Dr. Timothy A Binder	pgs	11-18
<i>Questing for Economic Models for a Peaceful and Sustainable Civilization.</i>	pgs	18-20
by Dr. T. A Binder		
<i>Summary of, Endorsements and Comments on Don Kelly's Gravity Drop Tests.</i>	pg	20
by Josef Hasslberger, Boyd Bushman and Martin Holwerda.		
<i>Update on the New World Gravity Wheel Generator</i> by Robert Cafarelli	pgs	21-28

From The Archives

<i>Russell Rent Mutualization Plan For National Rent Relief - Universal Home Ownership Through Normal Rent Paying</i>	pgs	29-49
by Walter Russell, Inc. 366 Madison Ave. New York		

Patent Papers

The Pogue Carburetor	pgs	50-56
----------------------------	-----	-------

Some Of Our Current State (+ & -) almost a half century after publication of *The World Crisis, Atomic Suicide?, etc.*

<i>Health & Healing</i>	pg	57
<i>Earth Changes</i>	pg	57
<i>Government/Politics</i>	pg	57
<i>Religion</i>	pg	57
<i>Art</i>	pg	57
<i>Science & Technology</i>	pgs	57-58
<i>Business & Commerce</i>	pg	58
<i>Agriculture</i>	pg	58
<i>Education</i>	pg	58
<i>Miscellaneous</i>	pg	58

Newsletters/Periodicals.	pg	59
-------------------------------	----	----

to a gyroscope or a top that has been in-putted with a tremendous centripetal charging thrust allowing it to remain upright.

The reason it is not affected by a magnet is that in the case Charles cites the vortex arises from an aluminum point electrode and the stream itself is made up of particles of aluminum. If my assumption is correct we might expect an iron point electrode to generate a stream that would be deflected by a magnet. The same reasoning holds for it not being affected by a nearby electrostatically charged ball.

The electrostatic generator creates a polarized condition which is a condition of imbalance that must seek balance and this generates the thrust. The shape of the generator point electrode surface is a factor in determining the shape and strength of the vortex thread as a pointed, rounded or blunt magnet determines the shape and strength in part of the magnetic field. What is observed is the same in principle to a block of ice and a hot iron placed near each other. There is a polarized condition in the temperature differential that seeks balance and a current flows from one to the other until they find balance of temperature.

If this is true then heat or temperature differential is also an electrical/gravity differential as well. If all there is, is motion towards or from a system center, or opening and closing spirals, in all the universe of many things, then heat, light, electricity, magnetism and gravity are qualitatively the same phenomena. The differences observed are quantitative and/or directional differences. Following is a brief philosophical non mathematical description of heat and its relation/identity to electricity/gravity: Temperature is one of the eighteen dimensions of the Russell Cosmogony. Greater heat manifests in a system center where motion is most intensely wound and bound and the resistance to the motion is greatest. This is also the area of greatest density, Gravity/gravity, electricity/magnetism, the greatest apparent ability to attract and repel, the greatest maturity and sex expression. The reverse is true at the periphery of a system/wave/. To change the temperature of a system/atom changes all other of its dimensions. Greater understanding of these concepts may hold a key to engineering Gravity, electricity/magnetism. Clausius's concepts of a one way only entropy Universe have blinded us.

With this hypothetical background I suggest that perhaps it is possible to engineer Gravity with heat as well as

electricity, magnetism and light, and to transform each phenomena into any of the others. Theoretically we should be able to "create" gravity control via heat, light, electricity or magnetism.

Letters to the Editor

18 October 1995

Enclosed my check for \$25 as payment for a subscription to FULCRUM.

I am interested in follow-ups to Dr. Binder's experiments in transmutation and in his work with the energy device as discussed in the article published Sept. 1992 in MAGNETS magazine. If a follow-up is in a back issue, I have no objection to the subscription starting with that issue.

I think a step toward a deeper understanding of the transmutation process could be taken were there sufficient quantities of product gases for mass spectrometer analysis. This, because is it possible that the nuclear transactions favor specific isotopes of newly formed elements. This, because if Louis Kervran's hypothesis (BIOLOGICAL TRANSMUTATIONS) that low energy transmutations take place via proton-neutron pair transfers from one atomic nucleus to another's. The coulombic imbalance between electrons and protons is coected by shifts in electron population.

In a Kervran-based scenario: a water oxygen atom 'unwinds' into deuterons - D1/1, three of these combine with oxygen 16/8 to form fluorine 38/19 - less abundant fluorine isotope. Similarly, an oxygen nucleus that loses a proton - neutron pair transforms into a nitrogen nucleus = 14/7, an abundant isotope. Accordingly, a run/mix would include fluorine, nitrogen, deuterium, hydrogen, oxygen and possibly calcium - because fluorine 38/19 + H O/1 yields Ca 39/20, a less abundant calcium isotope.

Kervran's proton-neutron-selecting 'Maxwell's Demon' were enzymes, in the Russell/Binder experiments the division was magnetically accomplished. Does Dr. Binder have an opinion as to how crossed magnetic fields accomplish the transmutations?

Cordially,

Erwin Krieger
Cincinnati, Ohio

Editors response:

I don't know **what response** Mr. Krieger received from Chester over **two years ago**, but I figured his letter could be of **general interest to *Fulcrum*** readers and will answer his questions **as best I can** now and comment on his thoughts about **the transmutation process**.

The article mentioned in *Magnets* magazine was published in an earlier *Fulcrum* (Vol.1#2) and there were several follow-up articles regarding the transmutation work that Toby Grotz, Ron Kovac and myself were engaged in over the last almost 5 years. The titles of these articles, authors and issues can be accessed by calling USP. All past issues of *Fulcrum* are available at \$7 an issue.

Mr. Krieger mentions the work of Louis Kervran who did decades of work in biological transmutations at least part of the time while employed by the French government. Georges Ohsawa the founder of modern day Macrobiotics collaborated with Kervran and then went on to demonstrate many laboratory transmutations that did not involve biological systems/enzymes. In the *Magnets* magazine and *Fulcrum* article, Vol.1 # 2, I write about Kervran's and Ohsawa's work and give my view of it based on my understanding of the Russell Cosmogony.

I understand that transmutation can and does occur under many different conditions. It occurs in biological systems all the time and it is the enzymes as Mr. Krieger mentions as Kervran postulated that provide the energy. I postulated they are, or they create, the magnetic field structures necessary to transmute. In Russell's thinking these field structures are electricity, they are Gravity, they are Light and they are motion of the one substance demonstrating patterns in eighteen dimensions including a gyroscopic plane angle of rotation. The fields manipulate this angle of rotation or they create the vortex shape corresponding to a particular element. Vortex shapes are and/or create different atoms. Vortex engineering is transmutation.

Very simply stated from one point of view the magnetic fields are the mold into which the energized (heated) substance to be transmuted is held while the substance assumes stability in the new pattern (it freezes).

In future issues of *Fulcrum* I intend to do a synopsis of

Kervran's and Ohsawa's work and relate the concepts to the Russell Cosmogony. If any readers have experience with this that they would like to contribute let me know.

1-15-95

Dear Chester:

Happy new year to you, your new bride to be and to all. I cannot express how much I appreciate your writing to me. You are a special person Chester.

I have not been able to progress as quickly as I would have liked. Time seems to be so short. So much to do. I wanted you to know that the gravity wheel has become a two fold design. I have not been able to put forth the necessary hands on mechanics to finish a working model for Dr. Binder, you and the University. The latest design, as I mentioned to Dr. Binder, utilizes both magnetics and gravity. Essentially, I have implemented gravity as a force in two separate functions to rotate a magnetic field. (The important concepts are three dimensional. Thought processes. The hands become the creator.) Both the moved weights and the falling weights have become rotational magnets interacting in a magnetic rotational field. I wanted the gravity wheel to provide electrical output directly within the rotating magnetic/weights fields and THEN provide a secondary mechanical output as well.

Chester, I'm inspired by this issue of FULCRUM. In Paul R. Jensen's UDT article, he said: "Free energy represents a spiritual transition.... not meant to be owned". In Elizabeth Nall's article she speaks of the realization of the Creator. In the transmutation experiments God is seen in the design of elements and matter. I believe that with these beliefs, all that can be dreamed or imagined shall become a reality.

I believe that when our thought (magnetic) polarities are aligned (tuned) to specific resonant frequencies within the Creator's design, a channel of energy is opened. This energy is UNLIMITED. This energy will replace all present day energy as we know it.

I believe the Creator's energy started as a simple thought polarity...Love. When I wrote the treatise on Infinite Magnetic Polarities, I BEGAN with the realization that our thoughts are electromagnetic and that specific polarities will resonate with the infinite polarities that

pervade all space and that a harmony of resonance will allow a channel to be created. I believe this is why Jesus said that the Creator is all around us, yet he cannot be seen with our eyes. The Creator CREATED all life and matter. The Creator is actually MORE real than we are because he created all life. Our thought polarities MUST be based upon TRUTH, HONESTY, LOVE FOR ONE ANOTHER and the realization that that which we cannot see in the fourth dimension of infinite polarity is the Creator. I believe Jesus knew the complexity of the science, of resonance, of harmony and the energy. But, the only way to explain the science at the time was God's laws. God's laws will ALLOW our thought polarities to resonate with specific frequencies as created by God to be infinite in depth and Love. Science today must and will come to this realization. All matter is resonance, rotation, electromagnetic effect. Life, by the Creator's design, is ever-changing. Positive. Can adapt. It has intelligence. This concept I believe, will bring mankind to it's knees. To become humble. To understand the absolute simplicity. Our thoughts can create or destroy. We can accept the positive resonance of the open channel of harmony with the Creator or we can isolate our thought polarities by greed, deception and so forth. The Bible becomes suddenly very powerful in this scientific context.

How different the world could be if humans understood the resonance. Understood holodynamic effect. Understood that thoughts could resonate with unlimited energy. Well, I believe Walter Russell knew this. Tesla knew this. Unfortunately, many greedy people have known this too. BUT, living water, good food, and education can rebuild the channel. The Creator is working through many people today. The world must change.

I have several articles I will send you. I have been guided to write about what I have been shown regarding living water and how plants provide cooling and a simple means to control weather. You have given me the means to help. I must try.

Sincere regards,

Robert S. Cafarelli
Tennessee

Editor's response:

Mr. Cafarelli wrote this to the past editor, Chester Hatstat

who has since been married to Nan Ryant and they have a baby girl now too!

I am including Mr. Cafarelli's latest design on the New World Gravity Wheel Generator in this issue of *Fulcrum* as I think it has merit and may work. We need to get a working model ASAP to see if it works in fact as it appears to in concept. The world needs it.

Next edition of *Fulcrum* will include an article by Robert Cafarelli titled " *Scalar Electromagnetic Cooling in Plants and Vortex Generators of Water.*"

Causes and Remedies of Oxygen/ Ozone Depletion

by Dr. Timothy A Binder

The Russell's predicted in *Atomic Suicide?* the gradual loss of all the oxygen of the planet to be first noticed in the upper atmosphere or the ozone layer. They did not give an explanation in terms that were satisfactory to science as they did not deliver their message in science's language and they expressed fundamental concepts unknown and contrary to science such as the transmutation of elements by radioactivity that science thought impossible, a whole cycle Gravity and thermodynamic concept, a new and expanded periodic chart of elements and more. In spite of this difference in cosmogony they attempted to get science to understand their new concepts so that science might comprehend and verify their predictions. Unfortunately precious few in the establishment read and comprehended their message. No one has verified their predictions regarding radioactivity and ozone/oxygen depletion in spite of the FACT that we have witnessed their prediction become reality although the possible mechanisms as advanced by science exclude radioactivity with one notable exception. Earnest J. Sternglass of the Radiation Physics Laboratory at the University Of Pittsburgh has advanced an explanation that is consistent with establishment physics for radiation being a factor in ozone depletion postulating it influences the chlorofluorocarbon's chemical binding up of ozone hypothesis that science currently now mostly accepts. Dr. Sternglass will be a keynote speaker at our September Symposium and can enlighten us more on this area of research.

We desperately need to verify the Russell contention. Here in brief form is their argument: Radioactivity is the ultimate fire. Fire and water are two complimentary polar opposites. Fire represents and *is* the disintegrative

death force in nature. Water is essential for all life on this planet. In releasing the ultimate in fire all over the planet in the form of countless trillions of microscopic radioactive particles as they are constantly being emitted from nuclear power plants and atomic bomb testings we are upsetting nature's balance and destroying the water/life of Earth. Water is a marriage of hydrogen and oxygen, a voiding of their polarized condition into a new entity that gives life. In destroying oxygen we destroy water/life and vice/versa.

What is a possible mechanism for this destruction? The Russells did not give a specific mechanism as to what happened to oxygen when it is exposed to radioactivity that I know of but the implication from their work is that it is transmuted into some other element or elements. They claimed that radioactivity 'loosened' all lower octave elements making them unstable. This language is similar to what we know of in the "Petkau Effect" where the oxygen atom is energized/ionized by radioactivity and becomes a "free radical" causing damage to biological cells.

Science claims that radioactivity causes elements to decay into other elements especially at the high density (ninth octave) end of the periodic chart, but it is not widely known in science that nitrogen has been shown to be "transmuted" under radioactivity to carbon 14 and tritium, both radioactive forms of lower density (third octave) elements. I have quoted D.S. Rawson in past issues of *Fulcrum* (Vol.2#1) from his book *Radiation and Nuclear Homeopathy* as to this effect of radioactivity. So the phenomena is not unknown to science. (Rawson was a physicist who worked for the British governments' nuclear power program.) All the many details have simply not been observed with enough intensity over time to see that these effects call for a re-examination of our fundamental concepts.

To me the Russell Cosmogony suggests that oxygen may be transmuted into higher octave stages of the same "idea". In other words oxygen may become sulfur and selenium as these are higher octave counterparts or older stages of the oxygen idea. These elements occupy the same gyroscopic plane angle of rotation or locking point in their wave in the higher octaves as does oxygen. If such a transmutation is occurring then all of acid rain may not be fossil fueled, it may be nuclear fueled as well.

Until all of this is verified and corrected we should

become aware of what we might do to protect ourselves from the damaging effects of oxygen depletion. I have read reports from credible sources such as *The Reaper* newsletter written and published by R. E. McMaster Jr. (P.O. Box 84901 phoenix AZ) that world wide oxygen levels have decreased significantly from its pre atomic age levels of approximately 21% to as low as approximately 8% in some of our large metropolitan areas.

The loss of oxygen that is occurring in our large cities no matter what we ascribe that cause to is a most important factor in the huge increase of disease that are witnessing. (Read the health/healing section of this issue for facts.) Our white blood cells use the free oxygen atom (a free radical) as a means to scavenge and clean up viruses and bacteria. With a loss of oxygen we should expect to see an increase in disease and we are seeing it.

Any discussion of oxygen depletion and health effects should mention that smoking decreases available oxygen levels in the bloodstream. The smoke contains carbon monoxide which binds to the hemoglobin in the red blood cell and effectively makes that cell useless for carrying oxygen - forever- the smoker needs to create another red blood cell to make up for the useless one bound up with the CO. Another even less known fact about tobacco smoking is that it is radioactive! I have talked to Dr. Edward Martell at the National Center For Atmospheric Research in Boulder CO who is my source of information regarding this issue. Apparently polonium a radioactive element is in the fertilizer used for the tobacco plants and the plant also has a natural tendency to uptake radioactive elements of all types. Therefore, it is in the plants and when smoked the radioactive particles stick to the lung walls with the tars and nicotine and continue to give off radioactive emanations and you know the rest of the story from there. Pre-atomic age tobacco as used by native Americans for ceremonial purposes did not have this radioactive element in it and thus we did not find lung cancer in any appreciable amount compared to after the bombs, the nuke plants and the polonium laced fertilizer. Native Americans used it very sparingly too. Dr. Sternglass has told me that the figures show that until the atomic bombing of Japan in WW2 and the introduction of man made radioactivity in huge amounts by bomb testings and nuke plants there was precious little lung cancer in Japan even though the Japanese smoked lots. You don't believe all of this? The end of this article has a one and a half page bibliography documenting the radioactive polonium in tobacco and

its carcinogenic effects on smokers that I got from Dr. Martell.

Dr. John Ray a Naturopathic Physician who lives in the south sea islands who initiated the Ray Method of iridology and point holding healing seminars has written me of some interesting observations he has made that he believes he now understands as due to radioactivity since studying the Russell's message. He observed a blue ring appearing in the sclera (the white of the eye) of sick patients in the late seventies and early eighties. He further noted that this was almost exclusively occurring in individuals coming from urban areas. In the later eighties he noticed that this was occurring in virtually everyone. Chernobyl exploded releasing the equivalent of between 200 to 400 Hiroshima type bombs worth of radioactivity into the planet's biosphere April 26, 1986. The next year the media announced that the ozone hole was much greater than computer models suggested that it would be.

I checked many patients over the last few years since he first informed me of the phenomena and I have not found one individual without this blue scleral ring. In the homeopathic materia medica carbo veg is a remedy for poor oxygenation that has the physical characteristic of a blue scleral ring. Perhaps it may be a remedy that might help us until we re balance the planet. I intend to do some clinical research using blood tests for CO2 and oxygen concentrations with the remedy and let *Fulcrum* readers know of results.

It appears incontestable to me that radiation is negatively effecting all of us and also that oxygen lack is doing the same. Our present way of life reduces our oxygen consumption in at least the following ways: Urban areas at least have less oxygen from our energy production (car engines, coal plants, etc.) and the entire planet from the destruction of its biomass. Dr. Ray noticed that people that did about four hours of aerobic exercise a day or who did pranayama yogic deep breathing exercises did not have the blue scleral ring. I do not know how much pranayama time was required. I believe pranayama should be more effective than aerobic exercise as the body is not requiring the increased amounts of oxygen that exercise demands. If there are readers who would like to examine their own eyes, verify the ring and then do regular pranayama, recording time devoted to this practice and report results to me I will publish the results.

Here is a simple breathing exercise that you can practice

that should bring beneficial results: Lie on your back and breathe in as deeply as you can. Fill the lower abdomen first, pushing the lower belly out making it round out and bulge out, then fill the chest as far as possible. When fully inhaled you can pause briefly and push the breathe lower even more into the lower belly rounding it out even more. Then exhale and force all air out by pushing/compressing the lower abdomen inward as far as possible.

You can place your feet together with the soles touching and knees bent outward for five of the rounds and then place the feet flat on the floor with knees bent slightly inward and touching for five of the rounds and alternate each way every five rounds until doing twenty five for a set. This stretches the hips affecting spinal alignment in a desirable way.

You can notice your spine on the floor and flatten and/or flex and extend as well as sideways move it back and forth at anytime during the inhalation/exhalation process to notice additional benefits in spinal self alignment.

Do this 25 times/rounds for a set. Do this at least once a day, ideally 3 times a day, and within a week you should notice results in increased energy. If you can do a set lasting 20-30 minutes. I have noticed results doing them only once a day for 15 minutes or even less. At the end of this article I also have included an abbreviated form of this simple pranayama breathing exercise with diagrams.

This exercise increases oxygen to the body/brain and it also works the abdominal muscles, but most importantly it exercises and stretches the diaphragm muscle. The stretching and strengthening of the diaphragm has significant energy effects on anyone who will practice its training.

Dr. Ray also noticed that the oral ingestion of oxygen supplements had some effect on the blue ring. I have used several forms of oxygen supplements in my practice for years for various infectious diseases with very good results. In treating a patient I also use other modalities, usually botanical and homeopathic medicines, but I feel that some form of oral oxygen supplementation will help most everyone at this time with little chance of negative side effects, although I must state the caveat that excess free oxygen does have negative effects. The question is how can a person judge what is excessive. In practice the only way likely for the average person is through

self observation, **experience**. Too much of anything is not good. **Too much of "free radical"** scavengers that are being so **widely promoted** today are also not good and I have **observed this in patients** who have taken them based on the **claims that we all need them**. Too many of these stop the **bodies balance** and use of free oxygen to scavenge **viruses and bacteria**. It appears to me that we need both in **balance and that is ever-changing**.

In any case I have found that hydrogen peroxide is generally most effective in acute infectious diseases. It can be purchased most anywhere. Ideally get "food grade" that has little to no preservatives. If it has no preservatives it must be refrigerated. In a pinch I have used regular drug store preserved varieties with good results. It should always be used at 3% solution levels using this concentration and mixing about a teaspoon in about a half glass of water and drinking it down and following this with a swallow of plain water. I have used anywhere from 5 to 25 drops of 35% food grade hydrogen peroxide in 8 oz of water. This procedure can be used once or up to two or even three times a day. **ALWAYS** take oral oxygen supplements on an empty stomach and wait 20 minutes before drinking anything but water or before eating anything. Once over the acute infection stop this form (H2O2) of oral oxygen supplementation.

There are several varieties of oxygen supplements available in health food stores or through alternative health practitioners such as electrolytes of sodium and potassium that I have used on myself and patients for months at a time with no negative effects and apparently positive ones. I have found chlorine dioxide to be more effective than others but it has a pronounced laxative effect and appears to be more irritating than the others.

I have used an almost 100 year old naturopathic remedy that is an oxygen/sulfur compound for years that is a most effective remedy for viral, protozoan, and bacterial infections of all types that is no longer available through normal channels. Sulfur is a harmonic of oxygen, as I have mentioned previously; it is an older stage of the oxygen idea and it has many oxidizing qualities. I intend to make this and the other forms of oral oxygen supplements I use available with directions for use to people generally within the next four months. Contact me for details if interested.

The general dietary directions that follow in the article on VDT (video display terminal) Terminal and TV

radiation emissions should assist the bodies more efficient use of oxygen no matter what its physical activity level or pranayama practice or use of oral oxygen supplements.

The ultimate remedy for oxygen depletion is to replace Nuclear Power with Hydrogen Power and other "free energy" over unity energy devices that the Russell's and other individuals have suggested and demonstrated for humanity. I have a limited number of copies of a book of "free energy" patents that I published many years ago available for those of you that might be interested in seeing and understanding more about this area of energy production. It consists of the patent papers on 43 some different over unity, free energy or alternate energy inventions and various newspaper articles about some of them. Cost is \$28 postpaid payable to Dr. T. A Binder within the USA. I will be publishing at least one of these patent papers in every future edition of *Fulcrum* until all are published here as well.

In addition we need to stop cutting down the forests of the planet and replace their uses for paper, building materials etc. with other sustainable non polluting alternatives such as the use of the water hyacinth as pioneered by Dr. Godofredo Monsod who spoke at the USP sponsored *World Balance* conference in 1989. Audio and video tape recordings of his and other innovative alternative technologies are available from the University. Call 1-800-LOVE (5683) for current titles/prices. A switch to sustainable organic and full spectrum mineralized soil agriculture is also needed to remedy our oxygen problems. The lack of vital oxygen carrying trace minerals is affecting plant, animal and human life adversely. Eating seaweeds daily for trace elements can assist individuals through the interim.

The last recommendation I have is to read and study *Atomic Suicide?* and then contact those you know who might influence the course of our future energy development with what you think they should do about this.

Publications on Lung Cancer from Tobacco Radioactivity and Indoor Radon Decay Products

1. Martell, E.A.: "Radioactivity of tobacco trichomes and insoluble cigarette smoke particles," *Nature*, 249, 215-217, 1974.
2. Martell, E.A.: "Tobacco radioactivity and cancer in smokers," *American Scientist*, 63, 404-412, July-August 1975.
3. Radford, E.P., E.A. Martell: "Polonium-210: lead-210 ratios as an index of residence times of insoluble particles from cigarette smoke in bronchial epithelium," *Inhaled Particles IV*, Part 2, 567-581, W.H. Walton, Ed., Pergamon Press, 1977.
4. Martell, E.A., S.E. Poet: "Radon progeny on biological surfaces and their effects," *Natural Radiation Environment*, K.G. Vohra, U.C. Mishra, K.C. Pillai, and S. Sadasivan, Eds., Wiley Eastern Ltd., New Delhi, pp. 283-289, 1982.
5. Martell, E.A. "The natural alpha radiation environment: A preliminary assessment," *Natural Radiation Environment*, K.G. Vohra *et al.*, Eds., Wiley Eastern Ltd., New Delhi, pp. 121-130, 1982.
6. Martell, E.A., and K.S. Sweder: "The roles of polonium isotopes in the etiology of lung cancer in cigarette smokers and uranium miners," proceedings, International Conference on *Radiation Hazards in Mining*, Golden, Colorado, October 5-9, 1981, M. Gomez, Ed., AIME N.Y. pp. 383-389, 1982.
7. Martell, E.A.: "Lung cancer risks from the radioactive decay products of indoor radon," *Colorado Radiology 2* (1) Winter, 1982 (University of Colorado, School of Medicine Newsletter).
8. Martell, E.A.: "Radioactivity in cigarette smoke," *New Engl. J. Med.* 307, 309-310, 1982.
9. Martell, E.A., and K.S. Sweder: "Properties of radon progeny aerosols in mainstream cigarette smoke and the alpha dose at segmental bifurcations of smokers," Special Workshop on Lung Dosimetry, 30th annual meeting, Radiation Research Society, Salt Lake City, April 18-22, 1982, *Current Concepts in Lung Dosimetry*, D.R. Fisher, Ed., PNL-SA-11049, pp. 144-151, February 1983.
10. Martell, E.A.: " ∞ -Radiation dose at bronchial bifurcations of smokers from indoor exposure to radon progeny," *Proc. Natl. Acad. Sci. U.S.A.*, 80, 1285-89, 1983.
11. Martell, E.A.: "Bronchial cancer induction by alpha radiation: A new hypothesis," proceedings 7th International Congress on Radiation Research, Amsterdam, The Netherlands, July 3-8, 1983, Paper C6-11.
12. Martell, E.A.: "Aerosol properties of indoor radon decay products," proceedings of the 3rd International Conference on Indoor Air Quality and Climate, Vol. 2, 161-165, Swedish Council for Building Research, Stockholm, Sweden, 1984.
13. Martell, E.A.: "Critique of current lung dosimetry models for radon progeny exposure," in proceedings, ACS Symposium Series, Vol. 331, **Radon and Its Decay Products: Occurrence, Properties, and Effects**, pp. 444-461, American Chemical Society, Washington, DC 1987.

HOW I BECAME YOUNGER

IN A HALF HOUR A DAY

SEND COPIES TO FRIENDS

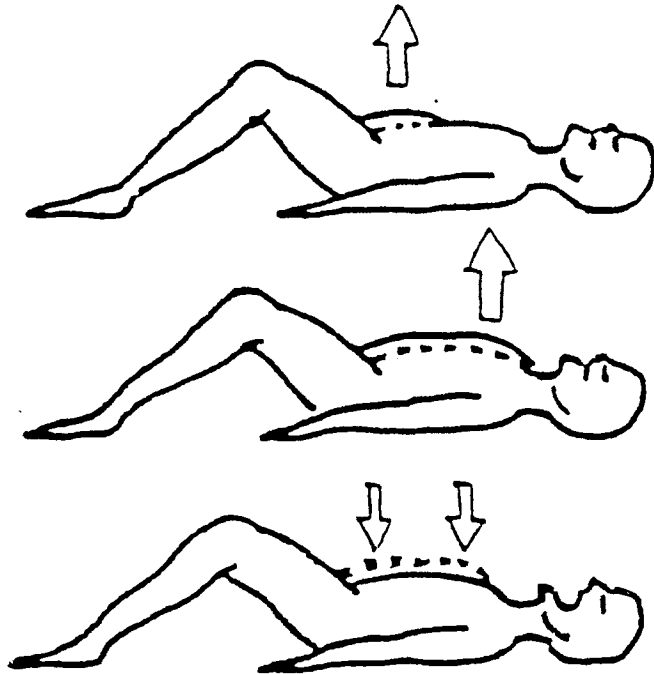

First half of inhale - lie on back, knees up, head not raised on pillow, inhale through nose only, mouth closed. Use first half of inhale breath so tummy only rises, not ribs, tummy stays up, then...

Second half of inhale - use second half of inhale breath so the ribs also rise. Breathe in all the way. Now both tummy and ribs are up, then...

How you exhale is important. Push the air out vigorously through a wide open mouth, like you were breathing on dusty sunglasses before you wiped them clean. Exhale all the breath out.

Just give it a 3-minute tryout! Don't eat or drink alcohol for 2 hours before. The buzzing, tingling feelings you'll have when you're through (honest!) will be a new and wonderful thing.

ARRANGE TO HAVE A FRIEND WITH YOU, their presence will help keep you going for the whole 3 minutes - right by your side, not in another part of the room. They can occasionally hold your hand, verbally encourage you, or give you a touch or caress. It really helps to get it done!

Lie still after, no talking, laughing, getting up, and moving around. You don't have to be completely still - you can lower your legs flat, remove a wrinkle from under you, wiggle a little to feel comfy - but if you have to yawn or clear your throat, do it as gently as you can. And, no "wake-up stretching."

The regular, full-length session is to do the

breathing for 20 minutes nonstop, the rest for 5 minutes. The intense, whole-body buzzing sensations you feel when resting are SO pleasurable, and they keep on going for most of the 5 minutes!

But, the most rewarding result of the exercise is that after 25 or so full sessions (don't do more than one a day!) you'll slowly and steadily find yourself liking new types of music, movies, etc., as well as liking all over again things you haven't in years... You'll gradually have new daydreams, ideas, interests, you'll feel more at ease in yourself, and you'll steadily become younger in your personality. It all has to do with gradually having the breathing muscle (diaphragm) relax, although I don't really know just why!

All these things are happening to me (honest!). It all surprises me so, but what a neat surprise!

The Dangers Of Computer Monitor/TV Radiation Emissions And The Protective Measures Available.

By Sandra Lee Reamer B.A., M.F.A. Candidate, Pratt Institute, NYC, NY, and Dr. Timothy A Binder

If you are exposed to cathode ray tube technologies this material can help protect or even save your life or the life of someone you love.

In my profession as an artist I also create and work with computers. My vitality has been reduced since I began working with computers in 1989. In 1995 I was diagnosed with a rapidly deteriorating health condition. With the help of an extraordinary physician, Dr. Timothy Binder, I have begun to orient my life style toward better health. In addition to treating my ills, Dr. Binder has brought to my awareness the dangers of radiation emissions generated in computer technologies. It is with this newly found insight that I embarked on a project to inform people about the dangers of VDT (video display terminal) technologies. I also wish to inform people about how to protect themselves and make these protections available as I found some of these are unavailable and those available are difficult to find. I am creating the material in a CD ROM (visually illustrated) form and the text will be published in The USP *FULCRUM* newsletter and other publications. This article is the result of interviews and discussions that Dr. Binder and I have had on the subject. My intention is to deepen your understanding of the hazards and nature of radiation so that you can make informed choices concerning your health. My hope is that once you have learned about the dangers of radiation emissions that you will continue to ask questions, take steps to protect yourself and choose not to remain silent, letting others know of this danger and the protective measures available.

In the Light,

Sandra Lee Reamer April, 1996

We will explore the history and misconceptions concerning radiation and then focus on 3 classes of radiation that are emitted from video display terminals and why these fields are harmful to you, citing literature to back up the observed harmful effects. Scientific evidence of the harmful effects as well as how to mitigate the harmful effects will be discussed. Most people do not have a deep understanding of how radioactive

materials and radiation emitting devices effect life on our planet. We will refer to the Russell Cosmogony that Russell students are familiar with and how it reveals the life and death principle and where radiation fits in the universal scheme of life.

In the beginning of this century the discovery of radioactive substances was misunderstood and naively announced and touted as health giving. Once discovered, **Radium Hot Springs** became the rage in the 1920's and 1930's. Bath houses sprouted up all over the USA and abroad boasting of healing effects of these radium hot springs. People traveled great distances not only to bathe, but also to partake of the bottled water which was sold as a health tonic.

A classic case of radium poisoning occurred in the women who painted with radium paint used in the luminous watch dials. Some of the earliest evidence that radiation was carcinogenic came from the extremely high instances of mouth cancers and leukemia or blood cancers in watch dial painters.

The early research of Madame Curie and her husband Pierre eventually informed us about the dangers of radium in the body. The Curies were scientists who discovered radium in the late 1890's. Throughout their experimentation they never became aware of the dangers of radioactive materials and took no precautions to shield and protect themselves. As a result of their research in refining uranium to isolate radium they ended up with cancers and other health problems. It was through the research of the Curies' and its effects on them that the dangers of radioactive materials was first demonstrated and better understood and thus the myth of radioactivity's health giving properties that was huckstered by commercial groups began to be confronted with the stark evidence of radiation's dangers. Despite the Curie's discoveries and unfortunate experience with radiation and the scientific evidence supporting the horrendous dangers of radiation, we are still unavoidably exposed to radioactive particulates from mining, nuclear power plants and atomic testing. As the main subject of this article addresses, we are exposing ourselves to harmful radiations from cathode ray tube technologies in the form

of VDT computers and TV's.

Humanity has observed the harmful effects of ionizing radiation from X-Rays and from radioactive metals from atomic testings and power plants over the last several decades. However, just as these radiation hazards were misunderstood in the earlier part of the century and still are misunderstood by a large portion of the populace today, the dangers from radiation emissions from VDT terminals is equally if not less understood due to lack of information about the nature of radiation and its causes and as a consequence the protective measures available are little known and appreciated.

When we work with or are exposed by proximity to electromagnetic technologies such as VDT terminals where we are exposed to their radiations, since the hazards are not revealed to us by the manufacturers, we must become informed by alternate and often underground or counterculture sources. The scientific research done on this topic tells us that the radiations emitted are dangerous, yet the industry producing the technology has yet to fully warn us of the hazards and to provide us with protective measures. If you are in an electromagnetic environment, even as a non-user of these technologies, you are still being exposed to X-Rays, ELF (extremely low frequency and VLF (very low frequency) radiation. Both ionizing and non-ionizing radiations have been found to have noxious effects on the human body. Lets look at these types of radiation more closely, at some of the evidence of harmful effects and explain the forces governing radiations, how we are exposed and ways to mitigate the harmful exposure and its effects.

Electromagnetic radiation consists of electric and magnetic energy fields that always exist together. In the Russell's terms the electric flow is gravitation towards the center of a system (atom, sun, etc.) to create mass and the magnetic flow is radiation away from the center of mass towards the periphery to disintegrate mass. Both of these are Gravity, or the complete life and death cycle of movement generally. Any device which uses electricity generates electromagnetic radiations.

Just as the ancient cultures taught, the Russell's taught that the universe is created, sustained and destroyed by the interaction of two forces: the generative windup centripetally directed life force and the radiative unwinding centrifugally directed death force. The Chinese and Japanese called the life force Chi or Ki respectively. The whole cycle of both life and death forces

is expressed in the Taoist yin/yang symbol. Both forces are necessary for a whole cycle of Life or the cycle of life/death. Understanding that all living things, and in fact all things, go through a coming into being integrating cycle and a going out of being disintegrating cycle lays the foundation for understanding how radiations of all types affect us.

There are generative forces such as the light from the sun that falls on this planet in a closing centripetally directed spiral that cause a plant to grow and there are degenerative forces such as the centrifugally directed opening spirals from radioactive materials that cause plants and all living bodies to die.

Even the sperm and ovum unite as a demonstration of the integrative life force that continues to cause tissues to integrate and grow a body. We have all experienced this life force when we are around healthy living things such as trees and flowers in a forest that make us feel more alive. When a body dies the constituent parts disintegrate and it comes apart under the expression of the radiative death force. The Chinese considered that to even look at a corpse would drain some of the vital life force from a living human being! We suggest that in the same vein to look at unshielded VDT terminals will drain off our vital force through being exposed to this same disintegrative radiative death force.

We can further understand this basic life/death process in considering the seasons. Fall and winter reveal a way to see the effects of the radiative disintegrative forces as they manifest decay. As we move from fall into winter, leaves are falling to the ground and the decay is apparent the moment they leave the branch or stem. The decay is due in part to the lack of sunlight which is the integrating form of radiation, and therefore the tree must let go of its leaves in order to survive and live through the winter. We can relate this to our own bodies and our daily waking and sleeping cycles. We need to sleep some every day to allow our bodies to excrete waste products and rebuild tissues. If we deny ourselves sleep or otherwise do not live so as to allow the integrative forces to rebuild us, we then experience excessive decay in our bodies which manifests as illness with a delayed and overabundant radiative discharge of toxic materials. We are then forced to rest and rebuild. In this way we see that both the integrative and the disintegrative forces are necessary to manifest life.

But, to expose ourselves to excessive disintegrative forces

is to invite overabundant breakdown and decay. Humanity is exposed daily to excessive amounts of these man made disintegrative forces from nuclear bomb explosions, nuclear power plants and from using VDT technologies as well as other of our civilized technologies. This is our inheritance from our modern civilization. Never before that we know of has humanity been exposed in such an excessively damaging way. The resultant effects of such exposure are evident in our increasing disease, lowering intelligence and social breakdown. But we can reverse it and even create technologies that are safe and that create life forces and more life for all of us. Some of these latter technologies that create life force will be explained in future editions of our work. Now lets look at the details of VDT technologies and exposure.

The terminology for measuring the fields are: electric fields are measured in volts and magnetic fields are measured in gauss. Hertz denotes the frequency or cycles per second for the appearance/disappearance of the field or how fast they change their strength.

VDT is an abbreviation for video display terminal such as used in computer technology.

Electromagnetic radiations range in the spectrum of "light" from cosmic rays to X-rays, through ultraviolet and visible light to microwaves and radio waves. The most energetic of these are cosmic, gamma and X-rays which are also called ionizing radiations. This kind of radiation inflicts heavy damage on the atoms with which it collides. This is a radiation whose energy is great enough to knock negatively charged electrons out of their atom, thus disrupting atomic structures and leaving positively charged ions behind, causing a variety of kinds of damage in the process.

Non- ionizing radiations include magnetic radiations such as radio waves and visible light which also have strong effects on living organisms but the mechanisms as we see their effects are certainly different. Rather than necessarily grossly damaging individual cells and molecules, they are more subtle in their effect to disturb normal biological processes. Even as far back as 1971 a presidential advisory committee warned that the environment was being saturated with non-ionizing electromagnetic radiation which poses a critical threat for human health.

High levels of electromagnetic radiation are present

wherever there are electronic machines such as computers and laser printers. Exposure to dangerous levels of these radiations depends on where you are in relation to the equipment and the length of time you are exposed. In the workplace the computer monitor is the most dangerous source because it can emit strong radiations and workers are generally close to the computer and stay there for long time periods. Steven Schechter author of *Fighting Radiation and Chemical Pollutants* recommends not to exceed 3 hours of exposure to computer technologies in a 24 hour period. Dr. Binder feels that in light of Dr. John Goffman's position that there are no safe levels of radiation exposure it is best to recommend that no one expose themselves to computers or TV's that have not been properly shielded as will be described later in this work. Dr. Goffman is a physicist and a medical doctor who is the author of *Radiation and Human Health*.

In a computer monitor, as in a TV, magnetic fields guide an electron beam that draws the image on the screen. In the process X-ray, VLF and ELF magnetic radiation is created that you will be exposed to. The closer you are the more exposure you get.

Contrary to what we might think, practically no ELF radiation comes from the front of the screen area of any computer monitor. Rather, it always begins at the neck of the picture tube and travels out away from the monitor in a typical electromagnetic arc shaped field. This ELF field is extremely powerful. ELF waves pass effortlessly through the computer monitor's base and into any body that is within 3 feet of the emissions field. ELF waves can pass through several inches of lead and concrete of any thickness, to say nothing of the human body. Radiation of this nature causes the cells of the body to vibrate up to 60 times every second or 3,600 times each minute.

VLF waves are also emitted from computers. There are potentially hazardous effects from VLF and gamma rays, but this has not been sufficiently documented at this point as far as the authors of this work are aware. Radiation emissions of this type are usually produced at low levels in our current technology. Damage to human health usually occurs over the long term as the dangerous effects from exposure are cumulative. If we listen to Dr. Goffman's advise we remember that he claims there are no safe levels of radiation exposure. Even the smallest dose of ionizing radiation can rip electrons free and set a cancerous cell in motion or lead to genetic mutation in

a future generation. Dr. Binder advises us that the cumulative and additive effects of exposure to radiations from all of the many recent human created sources as well as exposure to chemical pollutants and poisoned and demineralized and devitalized foods on top of the stress of our "civilization" should cause us to pause and consider that we should make every effort to mitigate our exposure to any radiation. He also encourages us to learn to eat vital food that fits our constitution and condition and learn how to transmute the stresses we cannot avoid through love, understanding and power of mind.

X-rays are ionizing radiations. John Ott D. Sc., the scientist who pioneered time lapse photography, studied the effects of X-rays coming off TV's and their dangerous health effects. Color TV emits approximately 3 times the radiations of black and white, but both emit radiations. These are coming from the screen area directly. The same technology used in your TV set is also used in your computer. Ott's studies tell us that X-rays travel and have effects at least 25 feet away from the front of the monitor or screen. There is additional scatter radiation that travels in all directions as well. Dr. Ott observed that fruit flies change sex under exposure to these rays. The inverse square law comes into effect in that the closer you are the ratio of exposure increases. For example, if I'm a foot away from a computer or TV I'll have half the exposure that I would if I were 6 inches away. The farther you are away from the machine the better.

Dr. Binder tells us that since we are exposed to the disintegrative forces of X-ray and /or VDT tubes, ELF and VLF frequencies, in addition to the radiations we have been receiving from power lines, microwaves, TV, other electronic technologies, and from nuclear power and bomb pollutants, disease has become more prevalent than ever. We can be sure that the effects of such exposures will weaken the immune system and cause living tissues to die. He cites facts such as that the Center For Disease Control in the USA admits that infectious diseases and deaths from these diseases has increased over 58% during the time period from 1980 - 1992 and that we must begin immediately to see and understand our Universe in terms of whole cycle systems, take actions to protect ourselves from the dangers we have created and learn to create new institutions and technologies that are in accordance with natural law. We need to understand and consider whole cycles.

As a consequence of not understanding fully the forces that we have been working with in our modern technology, today many people face the immediate menace of increased exposure to radiation emanations from sources in their home environment and work place. No matter where we live, all of us are affected to some degree by our modern electronic, nuclear and other technologies. Numerous health hazards have been documented by doctors and researchers who have studied and recorded the effects of electromagnetic fields on the body. As we have discussed, a source of ELF, VLF and X-ray emitting radiations is from video display terminals as found in TV's and computers. On a molecular level this radiation can cause damage to virtually any of the molecules of which our cells are made. All our living cells emit electromagnetic fields. Scientists have expressed that the field emissions from man made devices interfere with the fields emitted from living cells. Although our cells have developed many kinds of repairs, one part of every cell is irreplaceable, the DNA. The DNA carries our genetic codes from generation to generation. The major form of DNA damage leads to long term cell malfunction in our bodies now and to mutations in future generations. Other damage is to cell membranes interfering with cell to cell communication and with maintaining proper balance between the substances that belong inside the cell and the substances that belong outside the cell. DNA breakage affects our health and the health of future generations in a significant way. Lets look at the parts of the body where we experience these effects.

The parts that are most vulnerable are those where the cells are dividing most rapidly, those that have the least chance to carry out repair before having to repeatedly grow and divide. Thus, the cells and organs where radiation damage is most apparent and problematic are those of the immune system, the gastrointestinal tract and the skin. These are, of course, our chief lines of defense against outside invasion, and the gastrointestinal tract is crucial in maintaining proper internal composition, rendering us particularly vulnerable if damaged. Frequent exposure to these electromagnetic technologies breeds cancer by exposing these fast replicating cells to the damaging radiations.

Scientific studies conducted during the 1970's and 80's indicate that these low level forms of radiation can cause cataracts, cancers, birth defects, brain damage and cardiovascular disorders. In addition many health professionals fear that such forms of energy have subtle

effects on the immune, nervous and endocrine systems giving rise to behavioral problems, nervous disorders and a wide range of other diseases.

VDT studies show increased rates of miscarriage for pregnant women (1.8 times the normal), fetal abnormalities, leukemia, male breast cancer, dermatitis and skin disorders of many types, headaches, cardiovascular disorders and brain tumors from both X-ray and ELF emissions. Doctors and scientists believe they also cause cataracts, blurred vision, memory loss, stress and interference with the body's natural electromagnetic fields. When we are exposed to this electromagnetic radiative force our cells unwind prematurely approaching death before their time. As the Russells warned us in their book *Atomic Suicide?* the radiative unwinding death force that is emitted from radioactive materials causes our bodies to age and die before their normal time and it is this same force that is emitted from VDT technologies. These radiations also give rise to an increase in the severity and frequency of the whole range of diseases by lowering our immune system potential and speeding up the death of all of our cells.

A study reported in a Swedish newspaper in September 1990 in VDT news said that electromagnetic fields emitted from VDT's cause mercury in amalgamated fillings to leak out at an excessive rate causing a bitter taste in the mouth and the possibility of disease from mercury poisoning. Researchers placed amalgam fillings 20 inches from VDT's and measured the increase of mercury mobility. Of the 5 VDT's tested, 3 of these caused a 3 to 5 fold increase in leakage.

Is what you feel real? Now that you are aware of what these disintegrative electromagnetic forces are and what they do, lets look at some examples that may relate to your experience while working on the computer. The more extensive the time period of exposure the more likely you are to notice these noxious effects. When you work on or around computers have you noticed your skin heating up, especially in the face and chest? In addition to the heating up perhaps you have experienced a dryness and/or burning in the eyes. These body experiences are due to the effects of the radiations on cells causing them to vibrate rapidly and also to explode abnormally fast. The rapid vibration causes friction and thus heat and this and the high energy from X-rays splitting electrons off of atoms can lead to miniature explosions in the cells. The body reacts to this increase in explosion and heat

by transferring the heat to the bloodstream and from there to the skin surface to dissipate it. However, as the radiation exposure goes on, the bodies ability to compensate and dissipate the heat diminishes. The molecular vibration, atomic disintegration, explosion and heat can give rise to a chain of biological events that includes the creation of what are currently called "free radicals" and other disintegration by-products that are part of the chain of events in disease and death. In fact the molecular vibration caused by these radiations is precisely how a microwave oven cooks food by causing atoms and molecules to vibrate with resulting friction and heat production which cooks the food

Lets focus on the eyes and see what the heating up process brings there. When the eyes are exposed to radiations their molecular structure vibrates more rapidly creating friction and heat. The X-ray ionizing radiation breaks off electrons from atoms due to their high frequency and bullet like behavior. This high vibration rate and splitting off of electrons is felt as a heating or burning in the eyes. The eyes are literally being shot with countless millions of tiny radiation bullets. The burning sensation is literally a burning. The rays hitting the protein in the clear lens of the eye literally heat and cook it. An egg white is made opaque through heating or cooking in the same way as the lens of the eye is progressively affected with radiation exposure and heated and cooked. We call a cooked eye lens a cataract and it can be made opaque by the radiations. Then it no longer allows light to pass through to create vision, thus blindness is the result.

We have discussed some of the health effects that we have been observing as a nation with increasing frequency such as birth defects, "spontaneous" abortions, cancers, leukemia, and numerous other diseases. Dr. Binder who is in agreement with Dr. Goffman tells us that there are no safe levels of ELF, VLF, and X-rays and that until it can be proven otherwise we should protect ourselves from exposure. "One does not need to be a medical doctor to appreciate that such electromagnetic phenomena which have no counterpart in man's evolutionary history are hazardous to health. Research continues to show that the only consensus is the lower the radiation emissions the better". David W. Sutton, A.A.S.

So, what are the options for people who want to work with VDT terminals for significant periods of time each day? A person should cut down on the exposure time

however they can. We can safely say that the exposures we are getting are not safe. Ultimately we need to deliver a message to industry that we want computers that don't emit any radiations. This is a problem that needs to be addressed as a nation, as a people. We need to reduce to as close to zero exposure as is possible. Therefore sit as far away from the monitor as you can. Remember the inverse square law comes into effect and the farther away you are from the monitor the less you will be affected. Move the key board away from the machine to reduce the intensity of the exposure by being as far away as possible. Don't sit next to other operating machines while you work. Don't sit in back of a machine someone else is using because you will still receive ELF radiation from the back and sides of it.

Another option is to use the existing technology available such as lead lined glass which can be put over the screen of the VDT computer or TV and will block about 98% of the X-rays. This is the same lead lined glass that X-ray technicians get behind to protect themselves while they expose you to X-rays for medical purposes.

In addition to the lead lined glass X-ray blocking shields, there are special metal alloy internal shields to block the ELF and VLF rays. The best of these shields blocks about 85% of them and the worst about 50%. Glare screens will not protect you from radiation emissions and will not stop the irritation to the skin and eyes nor any of the other noxious effects of radiation exposure.

The third category of protective devices are those that are supposed to in some fashion override, blanket or harmonize the offending radiation with another protective electromagnetic field. Some of these such as the Teslar watches are supposed to put out a field in the 7.8 hertz frequency range that corresponds to the alpha rhythm brain pattern. Others are supposed to organize "chaotic" or "random" radiation fields into organized fields that then become beneficial. We assume by this language that in Russellian terminology they mean they change radiative fields to integrative fields.

This last area is a gray area to the authors of this article in that they do not have access to experimental or measuring data that can substantiate beneficial effects or even enough theory that appears to be consistent with the cosmogony just presented to suggest that the harmful radiations can be somehow transformed into even harmless let alone helpful radiations. Future articles will present more information and any test data we can

uncover regarding these devices. Information regarding these devices is also available from "Rrat" a company next to be described that provides Radiation Attenuation Transformation shielding devices.

Radical Radiation Attenuation Transformation (Rrat) is a company that produces and markets the radiation shielding devices previously mentioned for the public. *Rrat*, as the company is called, can provide you with additional information regarding the various sizes of lead lined glass X-ray shields for the VDT screen and the ELF/VLF shields that are strategically placed inside your computer, as well as ordering information and prices. You can contact them for this information at the following address: *Rrat (Radical Radiation Attenuation Transformation)* 173 Blodgett Camp Road, Hamilton MT 59840 phone# 406-363-4041/3617.

Another option other than the external and internal shields is liquid crystal display computers which significantly reduce ELF/VLF emissions to a very low amount and eliminate virtually all X-rays. We do not know of any studies on the amounts of radiations emitted from liquid crystal displays or of any studies on harmful effects observed at this date. We will inform readers of this work of any future information in this area we might discover. Liquid crystal display technology is presently used in personal computers such as the Apple Macintosh Powerbook.

Nutritional protection options are also available to attenuate the harmful effects of radiation. Proper diet alone will assist to protect against radiation exposure and most American's do not eat enough fresh foods, let alone organically grown foods on mineralized soils that are full of protective vitamins, minerals and enzymes. The usual foods consumed that are grown on demineralized soils that have been further poisoned with chemical synthetic fertilizers and toxic sprays lack much of what can be present in healthy foods to protect against radiation's noxious effects.

In general, an organic whole foods diet that provides ample amounts of trace elements has the potential to enhance radiation damage protection. A diet as follows will minimize the current absorption of toxins and assist to detoxify the body after routine exposures to radiations or chemical pollutants. Whole grains 40% of the diet or 2 to 3 servings of them daily; vegetables 25 to 35 % of the diet or 2 to 3 servings daily with at least one serving per day of chlorophyll rich vegetables; beans and

legumes or foods such as tofu and tempeh 5 to 10% of the daily diet or one serving a day; sea vegetables 2 to 5% of the daily diet or one serving a day; 3 to 5 ounces of fresh fruit a day or one serving or 5% of the daily diet; non-hydrogenated fats and oils should provide about 10% of the daily calories in the diet or roughly 2 to 6 tablespoons a day. If you eat animal foods they should be organically raised hormone free and should be taken out of the beans and legumes amounts of foods consumed.

Particularly desirable foods include buckwheat, brown rice, millet, garlic, onions, cabbage, broccoli, cauliflower, locally grown fresh fruits and berries, green leafy vegetables like romaine lettuce, arugula, chards, fresh nuts and seeds of all sorts, seaweeds, organically raised organ meats, fermented foods such as miso, sauerkraut, tempeh, and traditional shoyu soy sauce.

Herbal tonics that can provide radiation protection include: Siberian and regular American, Chinese and Korean ginsengs, chaparral and aloe vera. Superfoods that also provide protective nutrients include: brewers' yeasts and biostrath herbal yeast, bee pollen, chlorella and blue green algae, lecithin and pectins.

The vitamins and minerals suggested will be helpful to take knowing that radiation exposure causes additional depletion. These superfoods, enzymes, vitamins and minerals can be purchased at most any health food store and *Rrat* recommended protective herbs, superfoods and supplements for those exposed to harmful radiations can be ordered from this company. The most important radiation protection agents, mainly because of their action as anti-oxidants, are the following:

Super oxide dismutase, catalase and other antioxidant enzymes have been shown to protect anyone exposed to ionizing radiation. Radiation exposure increases free oxygen radicals in the body and the oxidation process is a disintegrative process, a burning of matter. These anti-oxidants protect against the damaging effects of free oxygen by allowing our bodies to burn at the rate that is normal in order to keep our biochemical processes going and yet prevent damage.

Beta carotene, 25-40 milligrams daily. This form is preferable to retinol or vitamin A, of which it is the precursor, because of its lack of toxicity and enhanced anti-oxidant activity.

Vitamin E, 400 to 800 international units daily.

Vitamin C, 500 to 3,000 milligrams daily in divided doses, possibly increasing to bowel tolerance in extreme exposure. Vitamin E, C and Beta carotene or vitamin A are especially good for gut protection.

Selenium, 100 to 400 micrograms daily.

Nutrients that are especially important for enhancing tissue integrity, the immune system and wound healing include:

Bioflavonoids, 1 to 2 grams daily with 1 to 3 grams of copper a day.

Ginseng and/or eleutherococcus 0.5 to 2 grams a day

Pantothenic acid, 25 to 100 milligrams 2 times a day.

Essential fatty acids, cold pressed or auger pressed oils, fish liver oils, nut and seed oils, 2 tbs a day.

According to available information these doses are safe as part of a long term program where exposure is ongoing. They should likely be taken along with a multiple vitamin/mineral supplement at least at the RDA levels to avoid imbalances from supplementing specific nutrients and to allow them to work synergistically.

Melatonin is an anti-oxidant hormone that can be of benefit for the individual who is having difficulty in sleeping, as VDT terminals and radiation interfere with sleep patterns. Melatonin has antioxidant qualities as well as the sleep enhancing benefits. It should never be used except when you wish to sleep. A normal physiological dose is 500 micrograms (1/2 mg.), but recalcitrant cases can use up to 3 to 5 mgs. as needed to induce deep sleep.

Who provides Radiation Shields and Nutritional Protections? *Radical Radiation Attenuation Transformation (Rrat)* is the only company that makes and markets both types of radiation shielding devices that are needed for full protection. The external x-ray shields are available no where else in the knowledge of the authors. The internal shields are available from a very few computer stores, but *Rrat* carries only the most effective shield available. This ELF and VLF shielding is installed inside the computer and inhibits 89% of this kind of radiation. The lead lined glass external shielding inhibits 98% of the X-rays. *Rrat* can provide testing evidence of what percentage of radiation is blocked with their products as compared to most other products. There

are a variety of internal shielding devices on the market and *Rrat* carries the one that has the highest power to block the radiations. When purchasing shielding it is important to know what percentage your shield is effective at. Some shields and devices such as glare screens suggest protection but in fact do not reduce harmful VLF, ELF and X-ray radiations at all, but only provide some other function.

In addition to the shielding *Rrat* also carries protective herbs and supplements which can be ordered direct from them as well as a CD ROM version of this article with visual animations incorporated to enhance the message.

This article has given you a wholistic perspective on the nature of radiations, the destructive radiations emitted from VDT/cathode ray tube technologies and their characteristics and modes of action as well as protective and supportive measures that can be implemented to attenuate and transform the deadly effects of these devices. It has also cited a very small amount of the scientific literature/evidence that has accumulated over several decades supporting the contention that these devices are a present danger to your health.

Selected articles pertaining to skin, pregnancy, general health and visual problems associated with VDT/ Cathode ray tube technologies:

“Skin Problems in Video Display Terminal Users”, *Journal of the American Academy of Dermatology*; October 1987; Vol. 17: pp. 682-6484.

“Terminal Dermatitis due to Computers”, *Cutis*; September 1986; Vol. 38 (3): pp. 153-154.

“The Effects of VDT Work on Urinary Excretion of Catecholamine”; *Ergonomics*; December 1988; Vol. 31 (12): pp. 1753-1763.

“The Risk of Miscarriage and Birth Defects Among Women Who Use Visual Display Terminals During Pregnancy”, *American Journal of Industrial Medicine*; 1989; Vol.15 (3): pp. 357-360.

“Video Display Terminal Use and Spontaneous Abortion Risk:”, *International Journal of Epidemiology*; March 1989; Vol.18 (1): pp.132-138.

“Video Display Terminals and Pregnancy. A Review”; *British Journal of Obstetrics and Gynecology*; May 1988; Vol.95 (5): pp. 446-453.

(A more extensive bibliography concerning the medically observed effects of VDT terminal and TV technologies are available for interested readers.)

A Quest for Economic Models for a Peaceful and Sustainable Civilization

by Dr. Timothy A Binder.

Is there an economic model that when practiced can result in a peaceful and sustainable civilization? I think there is. The Russells gave us the answer in its simplest form as the basic principle of equity and balance. Perhaps more to the point they suggested that it would result as a state of consciousness, an ethic and habit of relating with each other. Russell students know the answer as rhythmic balanced interchange or the love principle. The Russells spoke of this principle and its implications for our civilization throughout their writings. In *The Home Study Course* they speak of the early Egyptian culture where the ideal was to serve your neighbors, and these people had no need to lock their valuables up as it was virtually unknown for anyone to steal. In *The World Crisis*, *The Dawn of a New Day in Human Relations*, *The Meaning and Acquisition of Wealth and Scientific Answer to Human Relations* they gave us examples of how by straying from Nature's way of balance we have created our various social and economic catastrophes.

In *The Dawn of a New Day in Human Relations* Walter Russell says we have been in process of learning several lessons, among them the fact that whatever we give to each other we get given back to us in kind. If we kill and steal we are killed and stolen from. Another great lesson is that we cannot hurt another without hurting ourselves and the whole world. Humanity's past actions of taking and killing for what we wanted have resulted in greater and greater wars. The greatest war that has been going on in the world for the last many centuries has been the war of the upper class against the lower class and vice-versa, with each periodically assuming the upper hand. The division of humanity into kings/serfs, capitol/labor with each trying to get the better of the other and assume the position of power has resulted in our greatest war.

In *The Meaning and Acquisition of Wealth* the theme is that we can acquire the wealth we want if we are willing to give of ourselves in service and goods for what we want. If we get material goods or service by bargaining

for the better end of a deal we will be impoverished in spirit and ultimately in material fact by the resentment if not retaliatory acts of those we impoverish.

In *Scientific Answer to Human Relations* they emphasize that peace and lasting prosperity can only come when we have as our ideal and actually practice giving for equal giving. Then in every transaction both sides are so satisfied that there is no residue of resentment left to contaminate and infect the system with war and strife.

The trick is how to demonstrate this basic principle in an economic system. How can we institutionalize this simple moral precept in an economic system? The implication from their work is that the system will occur as humanity's consciousness evolves and we *know* God's ways and processes and model them in our own ways and processes. Their part in the evolution of consciousness was to write as clearly as they could about the basic principle and teach us in this way how we all can change the world through understanding and practicing the law of balance/love in all of our actions.

If enough of us can change our actions to conform to the Creator's ways then this will change others and on and on until we reach a point of critical mass and change our institutions to conform to what we know and practice as rhythmic balanced interchange.

In the Quest for a definitive vision for an economic system that conforms to rhythmic balanced interchange that can become institutionalized, I suggest the following ideas as seeds for the more mature model to be birthed: 1) Our present system is based on debt. The word debt has the same root as the word death. The idea behind a debt system was articulated well by Thomas Malthus in the 1800's who was the head of the British East India Company at that time. Malthus had access to all of the world's resources and he perceived (with incomplete vision) that there was an increasing population on a finite sized planet and diminishing resources. Therefore, he reasoned grab all you can while you can. The idea was that there is not enough to go around and the only way to win the economic game was to get others in debt to you and/or to live off of their labor.

As Buckminster Fuller pointed out, as well as the Russells, humanity's greatest resource is humanity itself, and that we are constantly building on the work of each other. Civilization is the accumulating potential of all of us, and we are doing more with less all the time and thus

we do not have diminishing but rather increasing resources. Fuller called this process ephemeralization.

It is said that the present economic system in the United States (and therefore the world) is likened to a gigantic monopoly game where if it could be played out to its end one person would own everything and everyone else would be in debt. It is not uncommon today to hear speakers on radio talk shows claim that the root of this game lies in the "Federal Reserve" Banking System. Many claim that the Federal Reserve is not really Federal in that it is privately owned and that the government borrows its money from this private banking system and of course must pay it back with interest and therefore the government can never get out of debt because even the money it must use under this system to retire the debt it must again borrow from the Federal Reserve System. If this is true then it would indeed appear that we can never get out of debt under such a system. The question is, is this true, and if so what can we do to rectify such an abysmal error. This is the trillions of dollar question.

There are apparently many other reasons that our country is now the biggest debtor nation in the world, that every US citizen is born in the position of being a debtor to the amount of over \$65,000, that less than 3% of citizens at retirement own their own home, and we have increasing inflation with periods of deflation or alternate boom/bust cycles, such as importing more than we export in goods and services, that the government spends more than it takes in, that people are willing to go into debt for most everything, but what is the root cause? Perhaps the root cause lies in our perceptions of wealth, our perceptions of what work is, our perceptions of how we are to acquire what we want, what we should pay for services to anyone or any institution and that indeed we have institutionalized our perceptions in a system that has resulted in greater and greater class division and conflict.

Here are more suggestions based on my understanding of the Russell's writings, about life and about economics on how to create a sustainable and peaceful economic system: 1) We need to institutionalize equity in place of debt. By this I mean that every transaction would be equal and balanced as close to immediately as possible. A Good or service would always be balanced by an equal giving in goods or services and no one would be in debt, resentful or fearful. 2) Money would represent actual goods and services in equity and balance. The creation of money and the management of a banking/ economic

system is in itself a service that needs to be regiven to, but it needs to be regiven in equity, not in debt. If it charges too much for this service, then it is the same as price gouging, and if too little it will function poorly from lack of resource. The benefits of money creation should be equitably shared. 3) The marketplace should be allowed to determine prices unhindered by monopolies of any kind. This is difficult. Power tends to accumulate in the hands of those who are industrious and cunning. If there is lack of consciousness in the minds of those who accumulate power, then they misuse it to grab more in excess. If we do not let the government control prices, then the industrious and cunning monopolies tend to do this. If we let the government control prices, it appears to have no clue as to how to do this equitably and the industrious and cunning monopolizers end up controlling the government/prices to their ends anyway. We need balance between government and free market controls to be effective as consciousness evolves. 4) There needs to be a great public debate, for decades if necessary, about these questions and we need to examine the role of education in creating an understanding of the principles discussed here that the Russells taught I believe fundamental knowledge such as the Russell teaching needs to be integrated in our educational system. Vol. 3 No. 4 of *Fulcrum* has an article titled *A Universal Education For Children Of All Ages* that outlines what I think our educational system should be doing. 5) We all need to examine these questions in regard to our national policies and support leaders who demonstrate comprehension of these universal principles by whatever means they have received their understanding. 6) Demonstrate the principles in our own economic lives. If we live the principles or “walk our talk” we should have what we want as well as what we need and be a gift that enriches all those we have relations with. 7) Spread these teachings and congruent teachings that enlighten humanity. If everyone understood what the Russells taught and lived it our system would change and become sustainable and peaceful.

In meditation several years ago I realized that any system, as say communism or capitalism, would work, if the people had Love in their hearts and demonstrated it in their lives. And any system would fail no matter how perfectly it was designed if the people lacked Love in their hearts. The evolution of consciousness to the point of realization of the love principle of balance is essential if we are to create an economic system that will end our quest and result in a sustainable and peaceful civilization.

Summary of, Endorsements and Comments on Don Kelly's Gravity Drop tests.

Don Kelly's work with magnetized and electrically energized objects and the speed with which they fall calls to question establishment science's fundamental concepts in physics. I feel that there may be clues to gravity controlled flight and more if we can understand the phenomena he has demonstrated. His work has inspired the questions for this issue to be hopefully definitively answered in the next issue.

SPACE ENERGY ASSOCIATION-SEA/US

Alternate Energy Systems

P.O. Box 1136
Clearwater, FL 34617
(813) 442-3923
FAX (813) 446-529

May 13, 1996

Peter Graneau, Ph.D.
205 Holden Wood Road
Concord, N.H. 01742

Dear Peter Graneau:

I need to advise you that you have not heard the LAST of these Gravity Drop Tests, of the 1992-3 time frame.

Although I readily admit that the last phases - of this project ie: the smaller (9"x9") drop - test plate results were flawed due to the low resolution / response rate for digital timer circuitry, the first all magnetic drop test plates, with the larger (20x22) plates were quite accurate, and within acceptable scientific standards, in my view:

The enclosed three endorsements of these G.D.T. results, are clearly supportive, in varying degrees, of the original test results, as noted.

We have a real double-standard in our present frigging, so called scientific establishments, ugh!, wherein if you don't have a Ph.D. behind your name, your work is considered to be of little or no value, while at the same time these various "installed" and credentialed scientists, sit in their ivory towers, believing that they have found all the answers to all of our pending scientific problems.

If this is the actual case, then why are we so behind in the normal progress in applied physics, which should be taking place as we move toward the next millennium??

There is now a growing mass of evidence to indicate that there is both covert and overt suppression of advanced new energy projects ongoing in the U.S., which will probably result in the exportation of this ongoing N/E technology overseas, which is now looming on the horizon, at this point.

If you believe that all this "suppression stuff" is a lot of bull, then would you please whisper in my ear why both former astronaut Edgar Mitchell, and Dr. Hal Puthoff, cancelled out as keynote speakers at the past I.A.N.S., at Denver, CO, on April 25-28/96.

WAKE UP, man, like the Titanic, the N/E field is about to get lost, mainly due to the lack of GUTS within the present ugh! scientific establishments in this country!

Sincerely,

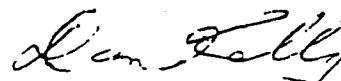

Don Kelly, for S.E.A.

SPACE ENERGY ASSOCIATION

P.O. Box 11422
Clearwater, FL 34616

Josef Hasslberger

Via dei Banchi Nuovi 21/B, 00186 Rome - Italy tel. (+6) 6868974 fax 6892407

Rome, 25, April 1994

Space Energy Association
Mr. Don Kelly
P.O. Box 11422
Clearwater, FL 3461
U.S.A.

FAX: 001 813 461 7119

Dear Don Kelly,

Thank you very much for your letter of 9 April with an enclosed paper to be presented at the International Symposium on New Energy in Denver, Colorado this coming May.

I think that with the introduction of AC energizing modes the experiment has entered a new decisive phase. It has gained tremendously in importance and should rightly have the attention of the scientific community.

With reason you call them "establishment pinheads" in your letter to Bruce DePalma. I think that once they have their diploma or doctorate or a nice chair in some university, these creatures think that the learning period is over and what's worse, in order not to fall behind, they try to stop, from their various positions of power, any new idea that might threaten the shaky edifice of their learning.

I have studied you last paper and put down some thoughts of my own to try and get a discussion going. If you think this might be of some use, feel free to use it as you please.

I would also be glad to see any comments you might have.

With kind regards

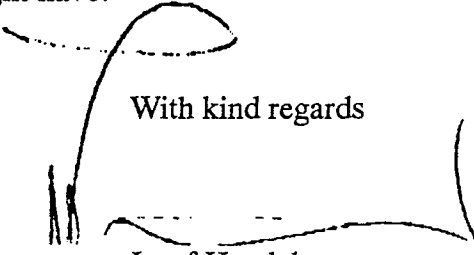

Josef Hassleberger

Comments on Gravity drop Tests performed by Donald A. Kelly of Clearwater, Florida

Donald A. Kelly, an independent researcher and consultant to the Space Energy Association in Clearwater, Florida, has been performing, from 1991 onward, an impressive series of test that measure the behavior of dropping weights in a magnetized or electrically energized state as opposed to their behavior in a non-magnetized (inert) state.

Various forms of magnetization and electrical energization have been used: Permanent magnets arranged both horizontally and vertically on test plates, electromagnets, non-inductive "Hooper type" windings, as well as a combination of permanent magnets with bifilar, non-inductive coils. The electric energization was achieved by direct current (12 Volts DC) as well as slaternating current (12 Volt 60 Hertz AX). Kelly described his results in various reports (1).

Work on these experiments is currently continuing with a view to investigating differences of behavior of dropping weights not only between DC current and 60 Hertz AC, but with various other frequencies and various wave forms of AC.

The apparatus used is a rack with a mechanical release mechanism and two micro-switches to activate a counter, as more closely described in Kelly's own reports.

The results have shown a significant lengthening of measured drop times in the magnet and/or energized state as compared to the inert/non-energized state of the weights (plates).

The following is a summary of results described by Kelly . Note that drop times are measured in digital counter units, not in analog time. The counter units

can be converted to seconds using a conversion factor of .00463.

We see from these results that a significant and consistent lengthening of drop time has been recorded in all magnetic and/or energized test plates as compared with the inert/unenergized controls.

No weight difference in stationary plates

A check has been made to ascertain whether between the energized and unenergized modes of the test plates, there would be an observable weight change.

No such change of weight between unenergized and energized modes was observed, measuring he weight of the plates, using an analog scale, noting he weight with and without connection to DC voltage.

Motion or acceleration?

The observed unequivocal lengthening of "travel time" of the test plates suggests that some interaction is occurring between a moving magnetic and/or electrical field and a "gravitational field" or a "space background."

The interaction is null as long as the test plates are stationary.

A question now arises: Is the observed effect a consequence of motion or is ti connected with acceleration?

The importance of this question might not be immediately obvious, so I shall try to explain.

If we are dealing with a resistance to acceleration,

Energizing Mode	Drop Time inert	Drop Time energized	Difference	Difference (percent)
Perm. magnet Flat mount	068	080	12	+17.6%
Perm. magnet vertical mount	084	122	38	+45.2%

we are witnessing an increase of inertial mass of the test object, determined by an electric and/or magnetic phenomenon, but without a corresponding increase in gravitational mass. This would be a phenomenon that is present without regard to motion as such; it would not be measurable unless the object is subjected to acceleration, regardless whether the acceleration is induced by earth gravity or by some other means.

If, on the other hand, we are dealing with a resistance to motion, we have to ask ourselves: resistance to motion against what? A resistance to motion would infer resistance against "changing of place" in relation to a (stationary) field or background. This could be a gravitational field or background of space (ether) thought of as a kind of stationary grid system, stationary with regard to planet earth in this case.

A third possibility would be to hypothesize that the motion of the energized or magnetized test plates in some way decreases the influence of gravity on the plates, actually leading to a change in weight (lightening) of the test plates only while in motion. This seems more unlikely, because a lighter test plate would not show such a large difference in drop time compared to a heavier but equally sized plate, as that shown in the experiments.

Conclusion

Whatever the force will eventually turn out to be, Kelly has made a discovery that must stimulate us to rethink some of the basics of physics in order to explain what is the mechanism responsible for the "abnormal" behavior of magnetized and/or otherwise energized plates.

I hope that this pioneering research will help shake contemporary physics out of its complacent lethargic attitude and initiate a wave of fresh thought that will lead to some real progress in magnetic propulsion, anti-gravity and more generally in space power generation applications.

Joseph Hasslberger
Rome, 25 April 1994

References:

- 1) "The gravity drop test connection to space energy conversion"
by Donald A. Kelly
(Paper submitted to the International symposium on New Energy, Denver, Colorado May 1994)
- "Gravity drop experiments"
by Donald A. Kelly
(Planetary Association for Clean Energy Newsletter, Vol. 7 No. 1)
- "Gravity drop experiments"
by Donald A. Kelly
(Magnets in your future, Vol. 7 No. 10, October 1993)

Suggestion for Drop Tests

In the "activity Update" of ESJ #12 both Charles Yost and Richard Hull report to have done some experiments in response to Don Kelly's drop tests. I would like to suggest that they continue these tests using a large flat tray and a blanc instead.

Kelly's test lead me to believe that gravity is caused by a left traveling vortex flow of the ether. Magnets possess powerful ether currents in both directions around the North-South axis that absorb the gravity vortex. This absorption is more effective when the antigravity device has a large diameter, because at the periphery the vortex is still weak and in an early stage of activity. Please consult both the NET 1992 and 1993 proceedings.

Martin Holwerda
Dordrecht, Holland

MEMORANDUM

December 12, 1995 *From: LOCKHEED/FT Worth*
** Div. Ft Worth, TX.*
 To: Distribution
** Boyd Bushman*
 From: Boyd Bushman
 Subject: RE-THINKING GALILEO: *- & Newton - ?*

(THE OPPOSING MAGNETIC ASSEMBLY FELL AT A SLOWER SPEED THAN ITS SAME WEIGHT COUNTERPART. Inside the 4 story windless atrium of building 500 a drop test was conducted from a height of 59 feet. The location was in White Settlement, Texas and the time was 12:20 pm. Two items were simultaneously released to free fall. Each assembly was 59 grams. One contained metallic weights while the other containing opposing magnets.)

Today at 12:20 pm the above weights were simultaneously dropped a distance of 59 feet. The experiment was again repeated. In both cases the weight assembly arrived to the floor ahead of the opposing magnet unit. The first drop was conducted at the higher location by the witnesses (below) and the fall arrival was observed by Mr. Bushman. The second falls simultaneously releases was achieved by Mr. Bushman at the higher location. The arrival was observed by the witnesses standing at floor level. In both occurrences the 59 gram weight assembly arrived to the floor ahead of the 59 gram opposing magnet assembly.

In the second drop the opposing magnets fractured into multiple parts terminating this first test. The magnets are Samarium Cobalt, one inch by one inch by 1/4 inch. Magnetic lines came out the larger faces.

The original Galileo experiments were properly conducted and in general the conclusions of, "The time of fall is independent of density", is correct. However, when magnetism is added, especially in opposition, the results of the Galilean conclusion are NOT accurate. The opposing magnet fall time was found to decrease.

Further confirmation tests need to be conducted. When the confirmation is quantified the effect can be studied to see how the following influences are effect:

- 1 - The earth's gravitation constant "g".
- 2 - The earths magnet field "B".
- 3 - An air molecule interaction. Many of the air molecules are small magnets.
- 4 - Some space related interaction.

Parallel with analysis the author suggests testing directed toward commercial application so this opposition magnetic force.

Robert A. Cafarelli

 Witness

12-13-95

 Date

Ernie Hale

 Witness

12-13-95

 Date

Update on the New World Gravity Wheel Generator by Robert Cafarelli.

See Robert's' letter to the editor in this issue for more details on the generator.

INVENTION DISCLOSURE

DATE 3-16-96

1.Descriptive title of invention GRAVITY/HYDRAULIC/MAGNETIC MOTOR

2.Full name of inventor ROBERT S. CAFARELLI

3.Current address 467 FLAG BRANCH RD.,GREENEVILLE,TN. 37743

4.Residence telephone _____

5.United States Citizen (yes) X (no) _____

6.(a) Date first conceived 1993

(b) Date reduced to practice model in process

7.Date of first public use, sale or printed publication 1994

8.Persons familiar with invention Michael Slavin P.A.

9.Brief description of invention a unique and useful
means of providing a motive force utilizing gravity in
two or more separate functions, hydraulic pressures to
enhance the movement of transported weight, a fluid as
the weight, pistons with sealing rings as weights, to
allow rotation of a structure by means of transporting
weight to the downward direction of rotation.Further
enhance of the rotation is the option of an external/
internal magnetic field at specific rotation position.

Attach drawing, description or photograph, if available.
The following documents are attached, numbered 1 to 2.

Read and understood by:
Michael A. Slavin P.A.
Date: 1993

Inventor signature



GRAVITY/HYDRAULIC/MAGNETIC MOTOR

PAGE 1

Inventor

Robert Caparelli

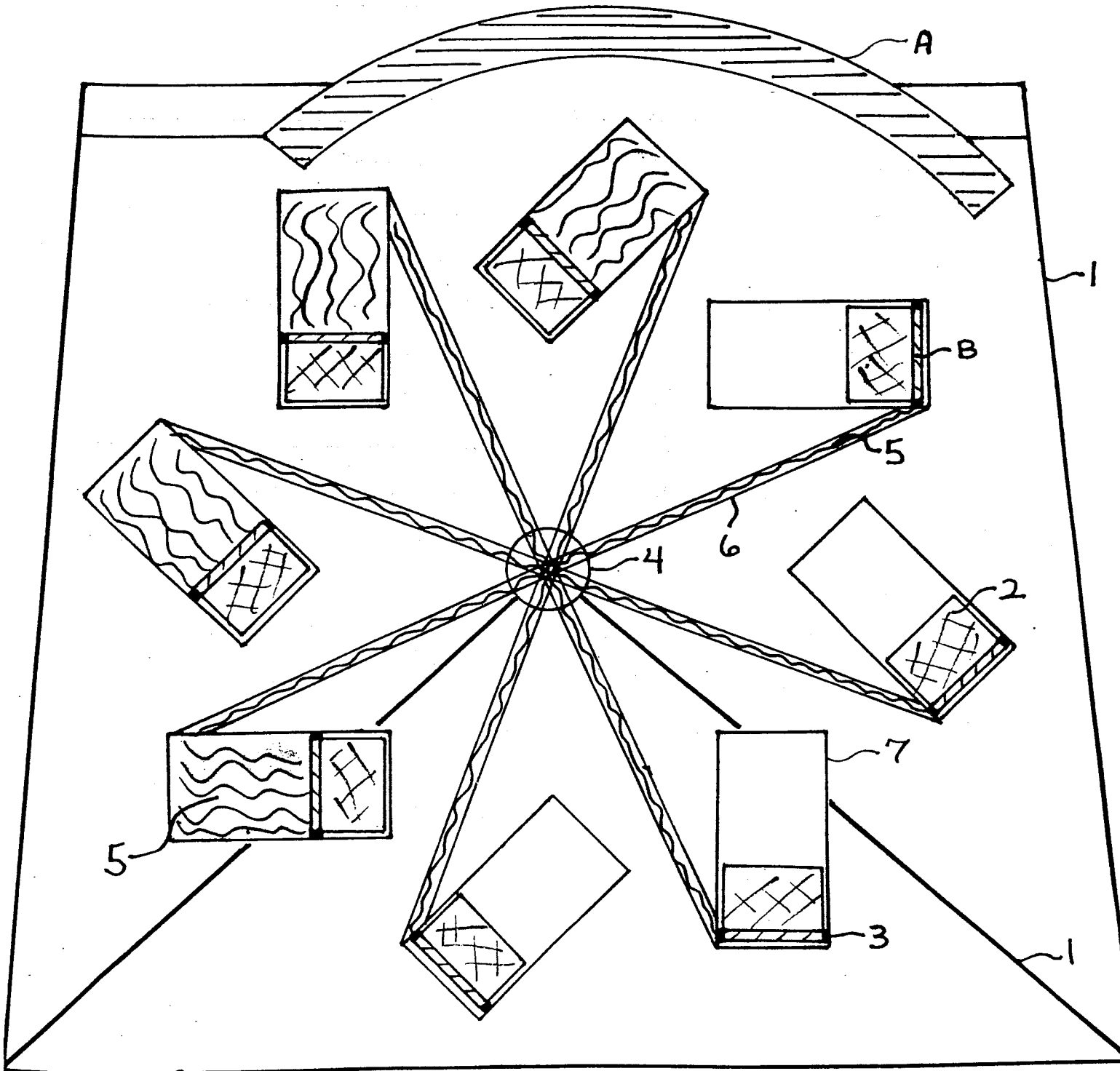

EXPLANATION OF DRAWING:

PAGE 2

- 1 support frame
- 2 ~~solid piston weight~~
- 3 piston sealing ring
- 4 bearing support
- 5 fluid weight-transported
- 6 fluid transport tube and support
- 7 cylinder

OPTIONAL MAGNETIC ENHANCEMENT

- A permanent magnet or electromagnet
- B permanent magnet

Inventor

Robert L. Farrell

From The Archives

The Russell Rent Mutualization Plan is an example of Walter Russell's thinking and actions on how to create a sustainable and peaceful civilization via economics. The several endorsement letters following Russell's plan also give some perspectives by artists on what art needs to flourish.

R U S S E L L

Rent Mutualization Plan

FOR NATIONAL RENT RELIEF

Universal Home Ownership
Through Normal Rent
Paying

WALTER RUSSELL, INC.

366 MADISON AVENUE, NEW YORK

Telephone Murray Hill 9308

Russell Rent Mutualization Plan for National Rent Relief

RENT MUTUALIZATION means universal property ownership through normal rent paying.

RENT MUTUALIZATION means putting a dividend paying value into rent receipts just as life insurance receipts became dividend paying through mutualization of the companies.

IT MEANS mutual ownership by all the people instead of individual ownership by the few.

IT MEANS the conversion of the waste of a lifetime into the savings of a lifetime.

IT MEANS participation by the rent payer in the potential value represented in the rent receipt.

IT MEANS gradual elimination of rent paying.

RENT PARTICIPATION would give back to the rent payer annually that share of the deed which his money has paid for after paying taxes, operating expenses, and fair service charges.

RENT PARTICIPATION should cut a man's rent in half in about seven years, or give him rent free and a substantial cash annuity in twenty-one years.

RENT PARTICIPATION rids one of the fear of dispossess when misfortune comes, for no one can be evicted so long as his participation credit is unused.

RENT PARTICIPATION gives a family two years free rent in the event of the death of the bread winner of the family while the present system gives not one day of respite from so dread a calamity.

RENT PAYING for a lifetime tends to impoverish a man, when, on the contrary, it should enrich him.

RENT PAYING to another owner is unnecessary when through co-operation the people can become owners of property and thus pay rent to themselves.

FOREWORD

I believe that an organized effort for National Rent Relief would be the most important movement of this century.

Twenty-five years of intensive study of real estate financing has convinced me that the present rent paying system is as pernicious as it is unnecessary.

Rents are mounting beyond the ability of the people to pay.

They have reached the danger point where the National Welfare is affected.

Twenty-five years ago ten artists of whom I was one, planted the seed of this idea through perfecting the co-operative ownership movement which has spread around the world.

The principle has been accepted as economically sound because it has proved itself so.

In the proving I have equipped myself with the technical knowledge and surrounded myself with highly specialized associates for enabling me to take this final step which I believe to be of epochal importance because it will ease the great burden of rent paying to a rent weary world.

It will rid old age of the fear of dispossession.

It will convert the waste of a lifetime into the savings of a lifetime.

It will mean better citizenship because it automatically will make of this country a NATION OF HOME OWNERS.

I would rather give this idea to the world than possess all the wealth of Croesus.

The one hundred founders who are joining with me in giving this idea to the world feel as I do and are lending their names and their support with the feeling that the beneficial effect of this movement to the people transcends all idea of financial gain.

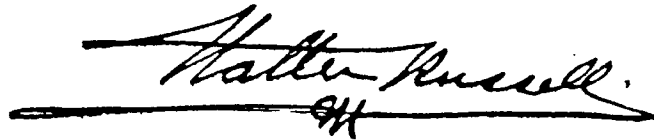
A handwritten signature in cursive script, reading "Walter Russell", with a horizontal line underneath. There is a small mark below the signature that looks like "RH".

If it pays a landlord to erect buildings for the people to rent it should pay the people to erect their own buildings and participate in their earnings.

Buildings are paid for by rentals but the rent payers do not acquire the property thereby.

From one-third to one-half of your rent goes into the landlord's pocket. *Rent Mutualization* would put that back into your pocket.

The tremendous spread of co-operative ownership throughout the world has demonstrated the economic soundness of the principle of combination and co-operation as applied to home ownership.

It is a conceded fact that collectively many people can easily do that which is impossible for the few. *Rent Mutualization* is merely the united strength of the many pooled together for the one common purpose of rent saving through rent purchasing.

RENT MUTUALIZATION IS THE FINAL SOLUTION OF THE RENT PROBLEM

Founders of the National Rent Mutual Company

Founders' Committee:

ARCHITECTS	SCULPTORS	PAINTERS
Thomas Hastings	Edward McCartan	Frank V. DuMond
Burt Fenner	A. Stirling Calder	Arthur Crisp
Harvey Corbett		Felix Payant
Donn Barber		Walter Russell

One hundred prominent people have been selected to lend their names and invest \$1,000 each to give initial impetus to this idea by becoming its founders.

These one hundred founders' names are prominent painters, sculptors, architects, musicians, literateurs, art patrons, financiers and those people of vision who see in this idea the betterment of the human race through improved living conditions, increased prosperity through rent saving, the promotion of better citizenship through universal property ownership, the architectural improvement of our

great cities by removing the conditions which limit our architects,
and the artistic development of the nation through preparing New
York to be the Art Center of the World.

The following have already become founders:

Arthur Ross Elis Prastan
Thomas R. Dree

Carrie Hastings 14 West 8

52 Vanderbilt Ave -
by Thomas Hastings

George F. Barnard
464 First Washington St

Howard Chandler Christy
Richard Barry 407 W 67 St.

McKim Mead White 101 Park Ave.

Gertrude S. Whitney 8 West 8 St.

Richard Le Gallienne

Irene J. Gross, Woodstock, N.Y.

At Home to get 130 N. 42nd St.
Russell B. Smith, 452 Fifth Ave

Gordon N. Park 137 E. 66 St.
J. Knowles Hare. 1 W 67th St

Samuel Adams Clark
139 E 45th St N.Y.C.
of Warren & Clark

Grace H. Britton

Lilian B. Mallory
Woodstock

Harold W. Rambusch
2 West - 45th St New York City

Louis R. Barras
President
Barras Construction Corporation
366 Madison Ave. New York.

Frank J. Du Mond

27 West 67th New York N.Y.

Felix Payant - 318 West 56 St.

A. Stirling Calder 11 East 74th

Edmond Mc Cartan ^{157 East} _{35th}

~~Henry J. Bullock~~

~~14 E 53rd St~~
New York

Wm. Walter 101 Park Ave N.Y. City
1 West 67th

J. Phillip Schmand

~~1 Broadway~~

~~Walter Russell~~

Alexander Brook Elizabeth H. Gross

THE WHITE HOUSE
WASHINGTON

August 16, 1923.

My dear Mr. Russell:

The President wishes me to express his thanks for your letter of August 15th and the interesting enclosure. He fully realizes the seriousness of the problem to which you are addressing attention and has been much interested in your suggestions as to measures for coping with it.

Most sincerely yours,

Geo. B. Christian
Secretary to the President

Mr. Walter Russell,
Hotel Des Artistes,
1 West 67th Street,
New York City.

RUSSELL RENT RELIEF PLAN

Rent Relief Is The Nation's Great Necessity

Living conditions are not only becoming intolerable because of HIGH RENTS but impossible.

Billions of dollars have been wasted by rent payers in the past which it is now proposed to save.

The Russell Rent Mutualization Plan proposes to save this unnecessary waste and credit its value to the RENT PAYER instead of to the landlord.

Simplicity of Plan

Nothing could be more simple. Like all great ideas it is a wonder it has not been thought of long ago.

It is based on the fact that RENT PAYERS PAY ALL BUT THEY DO NOT GET ALL.

They only get rent receipts and the landlord gets the deed which the tenant's money has paid for.

There is not the slightest reason in the world why a tenant should not have what his money has paid for, because by uniting together for that one purpose nothing can prevent him from having his share of the deed for every months rent paid by him.

Some Interesting Facts About Rent Paying:

When one carelessly tosses a rent receipt in the waste basket one never realizes that fully one-third of its face value is potentially locked up in it.

Rental charges are based on one-third excess over all operating charges and interest on total investment.

This one-third excess is to buy the property for the landlord who usually doesn't own it until the tenant buys it for him.

Therefore every seven years that you pay rent you buy the equity in the property you live in.

You buy the deed with every rent receipt you get.

You give the deed to another and he gives you in return a worthless scrap of paper.

If you move out of the property you have bought you cannot take a door knob with you because the landlord has the deed and he can rent again.

If you pay rent for twenty-one years you have bought the property three times over yet if you fail to pay your rent you can be put out into the street, bag and baggage.

Rent paying is a habit of the mind.

It is a tradition which the mind has gotten into the habit of thinking is a necessity.

All habits are necessities until they are broken.

All habits are of the mind and are more easily broken by forming others to take their place.

The rent paying habit can be broken by thinking *rent purchasing* instead of *rent paying*; *rent saving* instead of *rent wasting*; and *rent participating* instead of *rent donating*.

By thinking thus constructively you will unite with others to make your rent payment purchase liberty and freedom from rent paying for old age rather than for buying shackles to make your own slavery to it the more binding.

In Unity There Is Strength

Civilization moves ahead only by giving dynamic force to potential idea thought out in the mind of man.

The way to transform potential idea into dynamic force is to double the number of people thinking the same thing and then re-double again one million times.

It then has an impetus which nothing can stop for it becomes a tradition in the mind of man, a habit of his thinking.

I thought out this mutual ownership idea twenty-five years ago but became convinced that its dynamic transformation had to be accomplished in two stages.

I first had to lift the co-operative principle out of failure into economic soundness.

This I did.

Now the world is ready for the next step.

Co-operative ownership paved the way for rent mutualization.

Co-operative ownership is for the few who have money while rent mutualization is universal.

Just as W. K. Vanderbilt had to have his \$10,000 car before the farmer could have his flivver, just so did I have to demonstrate the possibility of mutual home ownership through those who had money before I could give it to the masses.

The idea of mutual ownership has therefore been transformed from potential idea in inertia to dynamic activity by the simple rule laid down herein.

A Nation of Home Owners

To take the next step I shall follow the same rule for it has unlimited power.

Archimedes said, "Give me a fulcrum and a lever and a proper place to stand and I can move the world."

Give me one hundred founders and the dynamic force of one hundred thousand people thinking and talking UNIVERSAL HOME OWNERSHIP through rent mutualization and I shall replace their old *rent paying system* with the new *rent saving system* for them.

The first step is to secure the one hundred founders and plan a demonstration building with their initial investment. McKim, Mead & White shall make the plans for this demonstration building upon a site now being selected.

The second step is to incorporate the idea which shall be done in September.

It shall be known as The National Rent Mutual Company.

Better Homes Make Better Citizens

This company shall be officered by men of much experience and will have an advisory board consisting of an architectural committee and of highly technical experts covering every important element which enters into building construction.

Capital \$10,000,000, divided as follows:

Founders preferred stock 8% cumulative.....	\$100,000.
Preferred stock 6% cumulative.....	4,900,000.
Common stock.....	5,000,000.
	<hr/>
	\$10,000,000.

The preferred stock is to be universally sold, preferably in small amounts with additional common stock as bonus.

This \$5,000,000. together with \$5,000,000. of temporary mortgage money will be invested in National Rent Mutual Buildings and filled with tenants who shall pay normal rents.

The first demonstration Rent Mutual buildings will be studio buildings, for the arts are sadly in need of proper housing, and the majority of founders are prominent artists who are once more demonstrating their ability to solve an economic problem as they did in 1900.

The National Rent Mutual Company acting as construction company and owner can save from fifteen to twenty percent of the cost of a building by eliminating all the present day extravagant methods of financing and secure better buildings by idealizing working conditions between architect and sub-contractor.

Tenancy preference will be given at first to stock purchasers.

New Ideas and Ideals In Financing

When a building is completed and filled with paying tenants and operated for at least one year a detailed and fully itemized statement of its exact cost shall be issued which shall show exact cost of land, construction, contracts in detail, fees to architects and others and service fees to the National Rent Mutual Company for construction.

It shall also show the exact income and cost of operation for that year including normal real estate service charge to National Rent Mutual Company for operating and management.

It shall also include an *insurance fund* to be set aside at the rate of ten dollars per thousand to give *two years rent free* to any family who loses their breadwinner by death.

This statement will show that approximately two-thirds of the gross income will be used to pay operating expenses such as taxes, heat and wages plus $5\frac{1}{2}\%$ interest on the entire investment.

Approximately one-third will be left as gross profits to be applied as hereinafter described.

Upon this statement of fact the National Rent Mutual Company will issue and sell serial $5\frac{1}{2}\%$ guaranteed bonds for 80% of the total cost of the building.

These bonds will be redeemed and cancelled at the rate of 5% of the issue annually beginning at the end of the third year.

This will give the Company four years of earnings to release its 20% of capital tied up part of which is cash capital and part service charge, or profit for construction.

I believe this plan of real estate financing to be more sound than any system now in vogue which requires mortgage investment, for the following reasons:—

1. Too often money is loaned for construction in excess of the entire cost for which a very high bonus is charged. This bonus falls eventually on the rent payer and is one of the contributing causes of high rents.
2. The owner of record who has the sole right to administer the property as he chooses, is not the owner in fact. The lending company is the owner in fact yet it has no voice in the administration of the property so long as the interest is paid.
3. The incentive for tawdry building is too strong under the present system and a too rigid enforcement of quality cuts off the patronage of the high rate lending companies which make such conditions possible.

I believe that National Rent Mutual Bonds issued against its improved property of a demonstrated value and wide margin of safety

which property shall be owned and administered by itself, will be safer and more marketable than any real estate bond on the market to-day.

Various reasonably safe real estate construction bonds are being marketed and sold by the millions to-day by lending companies whose investors have not the security which these bonds will give nor the popular appeal for their purchase.

Division of Gross Profits

Now regarding the one-third gross profits left over from rental income. Out of this one-third a depreciation fund, based on two percent of the cost of the building shall be set aside for replacement.

The balance will represent net profits.

Rent Mutual dividend paying participation certificates will be issued for 90% of this amount and given to the tenants in the exact ratio of their respective interests.

Participation certificates will equal in value the common stock of the company but will be non-voting.

The remaining 10% will be retained as the company's share of net profits.

Earnings of the Company

The earnings of the National Rent Mutual Company will be seven-fold as follows:—

1. Service charge for construction, normal fee.
2. Service charge for management, normal fee.
3. Service charge for sale of its securities, less than normal fee.
4. Sinking fund for guarantee two years free rent.
5. One-tenth of net profits.
6. 25% of the common stock of all subsidiary companies desiring to operate under its guarantees.
7. Interest savings on redeemed bonds.

{ ROBERT VONNOH SAYS: }

"I do endorse the general trend of your ideas, and trust you will succeed beyond peradventure so that you can further the ideals and aspirations of the artists and their adherents to the point of rendering signal and distinguished service to art and to economics."

Earnings of Tenants

The earnings of the tenants will be twofold, as follows:—

1. Nine-tenths of the net profits paid in stock of the company.
2. Pro rata share of all the company's earnings in accordance with the amount of participation certificates held by them.

Thus it will be seen that the tenant shares not only in the net profits but also in the profits of construction, management, financing, earnings from subsidiary companies, and interest savings on redeemed bonds.

It is as though the tenant was taken into partnership not only with his landlord, but the construction company which erected the building for his landlord, and also the bonding company which financed the construction for his landlord, also the real estate firm who managed the building for his landlord; and also the landlord's side partners who desire to make use of his business strength and prestige.

A Truly Mutual Company

And therein lies the whole crux of the situation, mutual interest between company and tenant, for the tenant is the "Company"

The "Company" is practically a trustee for its tenant stockholders whose surplus rent money is pooled together for the one purpose of gradual extinguishment of rent paying and the accumulation of life income for old age.

Insurance Feature

One of the greatest Mutual advantages of Universal Home Ownership is in the distribution of the burden of individual misfortune through death over the entire community through its insurance feature.

When the bread winner dies his family cannot be put out into the street but may live there for two years, gratis, without any feeling of obligation whatsoever.

This is not charity nor philanthropy. It is just plain co-operation, for the nominal cost of making this possible is shared by all and is charged to operation expenses just as fuel and taxes are.

The lifting of so heavy a burden of worry and distress from the mind of man should make this world just a little better place to live in.

Typical Example in Figures

The following figures give a normal demonstration based not only on what has been and is repeatedly being done but can be done without end.

At a time when building costs are high rents are also high but relatively they average the same.

During the last twenty-five years I have found the cost of a building to be about six times one year's rent allowing reasonable profit for construction and without paying heavily for borrowed money.

Unusually high profits and high bonus fees for financing bring cost up to seven years rent.

The National Rent Mutual Company will build for moderate fees and will pay spot cash thus avoiding payment of bonuses. It is, therefore, safe to say that the cost of its buildings will approximate six years rent.

{IDA TARBELL SAYS:}

"I believe thoroughly in the soundness of your "Mutualization Plan". It is a natural development of the principle of co-operation. . . . There is no doubt that it will do what you claim—convert waste into saving, put into the pocket of the owner that which now goes into the pocket of the landlord."

Analysis of Cost, Income, Outgo and Profit

EXAMPLE:

Cost of nine story building 100' x 97' Eastside near Lexington Avenue also Westside near Seventh Avenue, including service fee.....			\$825,000
Income from rents.....			\$141,000
Cost of Operation:			
Labor—2 doormen, 3 elevator men, 1 fireman, 1 porter, 1 relief man, 1 superintendent....		9,100	
Fuel, electricity, water, supplies, repair, mis- cellaneous and insurance.....		10,600	
Interest of Company's equity of \$165,000 at 5½%		9,075	
Interest on mortgage bonds of 660,000 at 5½%		36,300	
		\$825,000	
Taxes.....		20,000	
Service fee for N. R. M. Co. at 3%		4,156	
Insurance at \$10 for each \$1,000 for two years rent free.....		3,704	90,934
			\$50,066
Gross profit (over 34%).....			\$50,066
Less replacement fund of 2% for re-investment.....			16,500
			\$33,566
Net profit (about 22%) which is to be used to amortize bond issue.....			

This net income will increase yearly by the amount of the interest on replacement fund which will annually be written off of principal and credited to the tenant.

Interest savings on redeemed bonds will be an earning of the company in which the tenant will participate pro rata in accord with his holdings.

It does not require much imagination to foresee the large reserve which the National Rent Mutual Company would accumulate through earnings in service fees, interest savings and re-investment of replacement fund on a large number of buildings such as this.

It can readily be seen that the tenant's participation in all the earnings of his company will be much larger by the participation plan than if he received his profits in cash.

DONN BARBER, ARCHITECT
101 PARK AVENUE
NEW YORK

August 3, 1923

Dear Mr. Russell:

Your rent mutualisation idea appeals to me very strongly as being economically sound in principle, and at the same time it is a stirring and far seeing vision, strong in material and spiritual possibilities.

It spells as well human and physical progress which should stimulate and encourage thrift, wholesome living, and civic pride.

It offers a new hope to the great mass of rent-paying Americans who at present seemingly have no practical means of becoming homeowners.

The average home must be made more attractive, comfortable, convenient and wholesome, it must be more permanent in character, and reflect better common sense in planning and investment.

Our future as a nation is bound to be shaped in a large measure by the character and intrinsic value of the homes we are building. The educational value of your scheme also appeals to me, and I take great pleasure in becoming one of your founders.

Very truly yours,

Walter Russell, Esq.,
366 Madison Avenue,
New York City

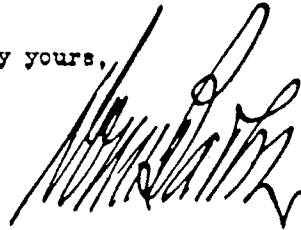

ARTHUR CRISP
1947 BROADWAY
NEW YORK

Walter Russell, Esq.,
366 Madison Avenue,
New York City.

My dear Mr. Russell:-

I see in the Russell Rent Mutual Plan the solving of the great problem of providing proper studios for artists and all followers of the arts upon a plan that will allow them to look forward to an ever decreasing rent whereas now they look forward to an ever increasing rent.

More than that I see it as the means for making New York the world centre of art.

Art like any other product of the human mind needs centralization and co-operation for its proper development of patronage. This is not possible under the present distressing conditions which scatter the artists far and wide over the boundless expanse of this great city like chips on the tide.

The Rent Mutualization Plan should be the greatest boon to art and artists, and because of that as well as because I believe I am making a very good investment I take pleasure in subscribing myself its first founder member.

I might add that even to this day I am greatly hampered in my art activities by the rent problem. If the Rent Mutual Plan had been operating sooner this would not be.

Yours very sincerely,

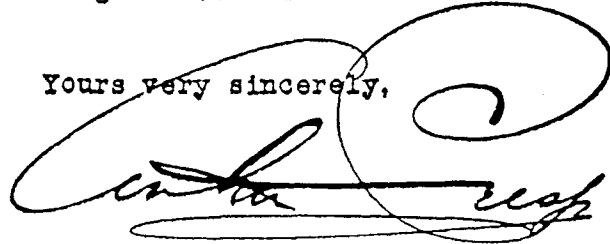

June 1st

1923.

ARCHITECTS REASON FOR ENDORSING RENT MUTUAL PLAN

Every Architect knows there are two general types of building operations. The first type of building is that built for permanent ownership, such as Public buildings, Banks, Memorials, private work for owners who expect to live in it themselves, etc. The other type is speculative building such as block dwellings, apartments, lofts and office buildings, which are built to sell.

The making of buildings to use ones self is quite different than from the making of buildings to sell, and the speculative builder who makes them only to sell does not have to maintain the standard even of a manufacturer of shoes. The shoemaker must have his first customer return for another pair. The building speculator never expects his first purchaser to return for another building. What is the result? The reputable trained Architect is practically unknown in the speculating building field because he cannot train himself to debase his art to the point of simply gilding the brick in order to further its sale as gold. Yet, by far, the major portion of all building operations of the present day are on the speculative side, and for this reason Architects of repute, design and supervise the construction of but a very small portion of the building work of the Country.

Practically every rent payer occupies space in a building created by speculative interests. What can the Rent Mutual Plan do for changing this situation? In the first place, it will turn the speculative type of building into the permanent ownership type. This will mean that all buildings now in the speculative field which come under the Rent Mutual Plan will be built with an idea of permanency and for beauty. It will establish new conditions which are now impossible owing to the short sightedness of Clients who are looking for quick profits and ignore future stability in construction and finance. It will give Architects a much freer hand to use the beautiful and unique in place of the usual tiresome cube form of buildings. Buildings with set backs and terrace gardens, varying levels and garden walls, will be the order of the day. The Architect and Artist know that beauty pays. The speculative builder does not know this. The Rent Mutual Plan therefore means that in time, the major building field which the reputable Architects now barely touch, will be open to him.

Helmler Corbett
Frank J. Helmler
Harry W. Corbett

Patent Papers

This patent is not a "free energy" patent like many that will be published in future editions of *Fulcrum*, but it is an energy saving invention that would allow any car to get much greater gasoline mileage. I present it here in hopes that someone will manufacture it and make it available for everyone. It could help humanity through the transition to "free energy" technologies. Also everyone has probably heard about the carburetors that were supposed to do what this one is claimed to do and here is perhaps proof that they really did or do exist. If it is a viable invention, why isn't it available? And the answer to that as Paul Harvey says, 'Is the rest of the story'.

This invention by Mr. Charles Pogue is a device which will change liquid gasoline into a truly vaporous state before entering the engine for the burning process. If the gasoline you use in your car were in a true state of vapor before entering the cycliners to be burned, theoretically, 200 miles per gallon is possible. The chemically correct fuel/air mixture for total burning of gasoline is 15 parts air to one part gasoline (15/1). You may even remember this from your school days, but did you know that this mixture ratio is by weight? Changing this to a volume ratio is as follows: 15 pounds of air is approximately 196.5 cubic feet (depending on altitude and temperature) and one pound of gasoline is .0222 cubic feet. Thus, 196.5 to .0222 is the same as 8850 to 1. To get this, divide one (1) by .0222 getting the figure of 45.045, now multiply this by 196.5 and you get 8851.3425, round this off to 8850 and you have a volume ratio of 8850 to 1 (8850 parts air to one part gasoline). Now this seems to make the pile of junk the automobile industry calls a carburetor a very inefficient piece of equipment - right? And that it is, 25% efficiency - and that ain't very damn good. The automotive industry hasn't changed the carburetor much since the days of the first automobiles.

Why? Because it works good enough to make their cars go, and research to improve the system is very very costly.

Mr. Pogue had his device patented way back in the 30's but whatever became of him and his device is unknown. To the best of this author's knowledge, and all our research can find, Mr. Pogue seems to have disappeared some time in the early forty's. Was he a fake, or was he bought off? We don't know but we suspect the latter. There are now over One Hundred Million cars in America and they use more than 75 Billion gallons of gasoline every year. Even way back in the 30's there were a lot of cars around, and we are pretty sure that the oil companies could see the future in gasoline. So ??? ...

Well at any rate, now for an explanation of how his device is to work.

BREEN MOTOR COMPANY LIMITED WINNIPEG

TO WHOM IT MAY CONCERN:

I made a test today of the Pogue Carburetor installed on a Ford eight-cylinder coupe. The speedometer showed that this car had already run over 8,000 miles.

I drove the car 26.2 miles on one pint of gasoline. The temperature was averaging around zero with a strong north wind blowing. I drove south for fifteen miles and back on the same road, and the distance as shown by the speedometer readings was 26.2 miles when the gasoline was exhausted and the car stopped.

The performance of the car was 100% in every way. I tested for acceleration, get-away from a standing start, and at all speeds, and it performed equal to, if not better, than any car with a standard carburetor.

At very slow speeds, under ten miles an hour, it was much smoother in operation than a standard car. In fact; below five miles an hour it pulled up a slight grade without laboring of any kind. I stepped on the accelerator when the speedometer was below five miles an hour and the car got away without a falter.

BREEN MOTOR COMPANY LIMITED
(Signed) T.G. Breen, President

FORD MOTOR COMPANY OF CANADA LIMITED WINNIPEG BRANCH

Mr. W.J. Holmes, 894 Wellington Crescent,
Winnipeg, Manitoba
Winnipeg, Manitoba, April 30th, 1936

Dear Sir:

Mr. Purdy and I appreciate very much your interest in arranging test for us with Mr. Pogue.

At the time the test was made we covered 25.7 miles on one pint of gasoline.

Before starting the test, the car was run until the motor stalled for want of fuel. The pint of gas was then connected; the main supply tank was turned off, and the test started from a stalled motor.

We are at a loss to understand the reason for such marked economy. However, every consideration was shown in carrying out test and acquainting us with the design of the carburetor.

Yours truly
(Signed) D.F. SMITH

This invention relates to a device for obtaining intimate contact between a liquid in a truly vaporous state and a gas, and particularly to such a device which may serve as a carburetor for internal combustion engines. Carburetors as commonly used for supplying a combustible mixture of air and liquid fuel is maintained in the liquid phase and a fuel jet which extends from said supply of liquid fuel and terminates in a passage through which air is drawn by the suction of the engine cylinders. On the suction or intake stroke of the cylinders air is drawn over and around the fuel jet and a charge of liquid fuel is drawn therefrom and broken up and partially vaporized during its passage to the engine cylinders. In such carburetors a relatively large amount of the atomized fuel is not vaporized and enters the engine cylinders more or less in the form of microscopic droplets. When such a charge is "fired" in the engine cylinder, only that portion of the liquid fuel which has been converted into the vaporous and consequently the molecular state, combines with the air to give an explosive mixture. The remaining portion of the liquid fuel which is drawn into the engine cylinders and remains in the form of small droplets does not burn and thereby imparts power to the engine, but tends to increase the cylinder head temperature above that at which the engine operates most efficiently.

I have found that the efficiency of a carburetor can be increased if the liquid is broken up and converted into the vaporous phase in advance and independent of the suction of the engine. I have also found that the efficiency of the engine is further increased if the previously prepared fuel vapors are caused to expand before being introduced into the engine cylinder and if a reserve supply of such liquid fuel vapors for introduction into the engine cylinder is maintained under slight pressure, so that when the conduit through which the vapors pass to be mixed with the atmospheric air being drawn into the engine cylinder is opened, the pressure will cause the gases to be forced through such passage and their introduction into the engine cylinders will not be dependant solely upon the suction created by the engine cylinders.

It is an object of the present invention to provide a carburetor in which the liquid fuel is broken up and prepared in advance of and independent of the suction of the engine and in which a reserve supply of dry vapors

will be maintained under pressure ready for introduction into the engine cylinder at all times. It is also an object of the invention to provide a carburetor in which the dry vapors are heated to a sufficient extent prior to being mixed with the main supply of air which carries them into the engine cylinder to cause them to expand so that they will be relatively lighter and will become more intimately mixed with the air prior to their explosion in the engine cylinders.

I have found that when the reserve supply of dry vapors is heated and expanded prior to being admixed with the atmospheric air, a greater proportion of the potential energy of the fuel is obtained and the mixture of air and fuel vapors will explode in the engine cylinders at the correct rate and without any apparent raise in cylinder head temperature.

More particularly, the present invention comprises a carburetor in which liquid fuel vapors are passed from a main vaporizing chamber under at least a slight pressure into and through a heated chamber where they are caused to expand and in which droplets of liquid fuel are either vaporized or separated from the vapors, so that the fuel farally introduced the engine cylinder is in a true vaporous phase. The chamber in which the liquid fuel vapors are heated and caused to expand preferably comprises a series of passages through which the vapors and the exhaust gases are brought into heat interchange relation with the vapors and give up a part of their heat to the vapors to cause their heating and expansion.

The initial vaporization or atomization of the liquid fuel is caused to a large extent by the passage of atmospheric air through a constant body of liquid fuel maintained in the bottom of the main vaporizing chamber, but for reasons which will be hereinafter pointed out, such vaporization of the liquid fuel is preferably supplemented by one or more atomizing jets, but the vapors from such jets are also caused to pass through the heating chamber where they will be expanded to have any liquid droplets removed.

The invention will be further described in connection with the accompanying drawings, but his further disclosure and description is to be taken merely as an exemplification of the invention, and the same is not limited thereby except as in pointed out in the appended claims.

Figure 1

8.23

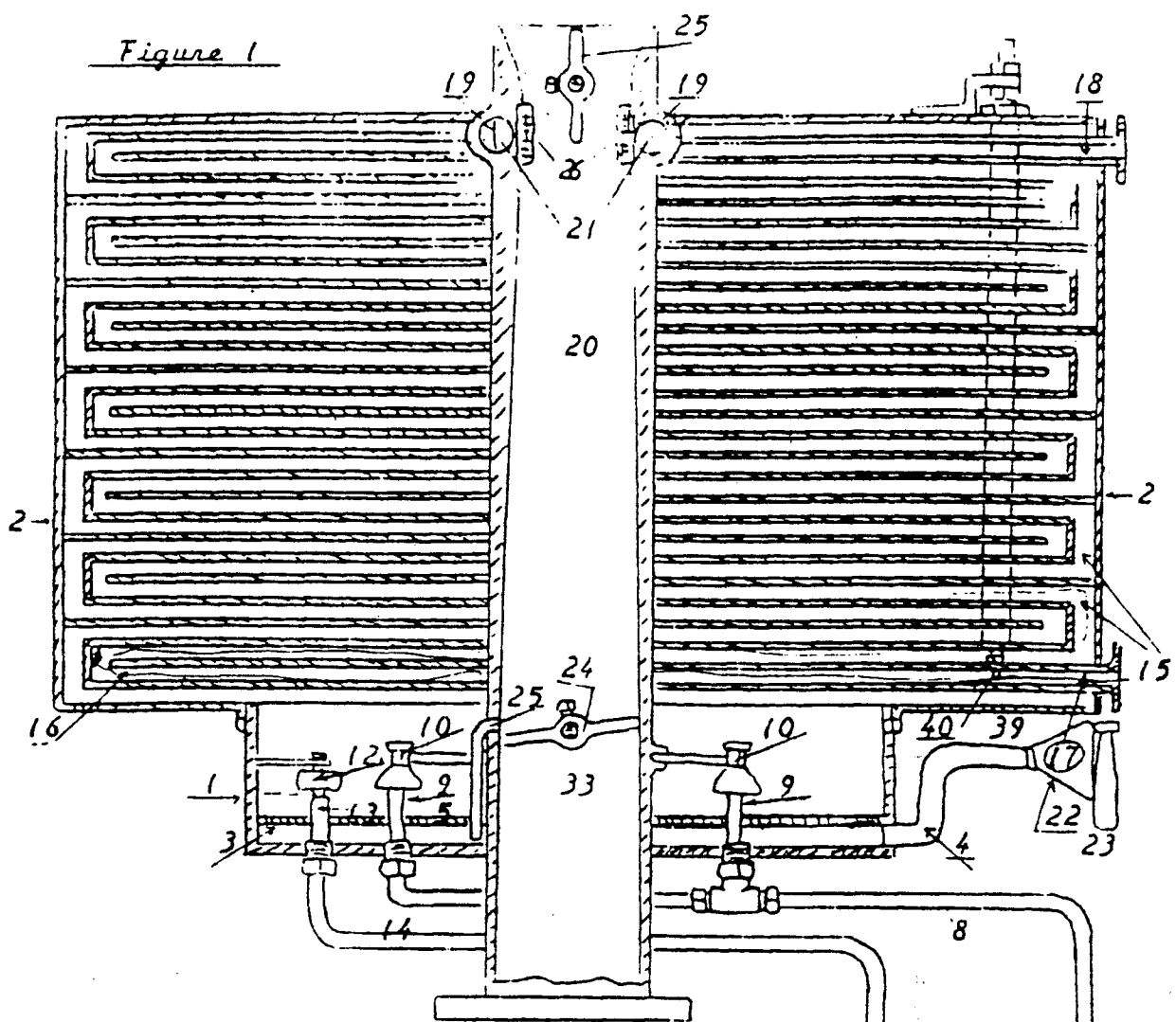
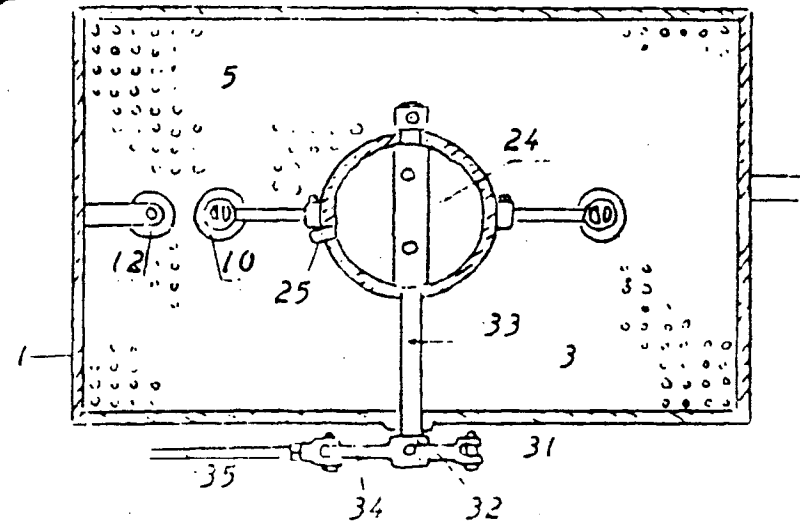

Figure 2



Carburetor 353538

Certified to be the drawings referred to in the specification hereunto annexed

Ottawa, January 3rd

1935

INVENTOR
Charles N. Pogue

J. B. Howling
ATTORNEY

Figure 3

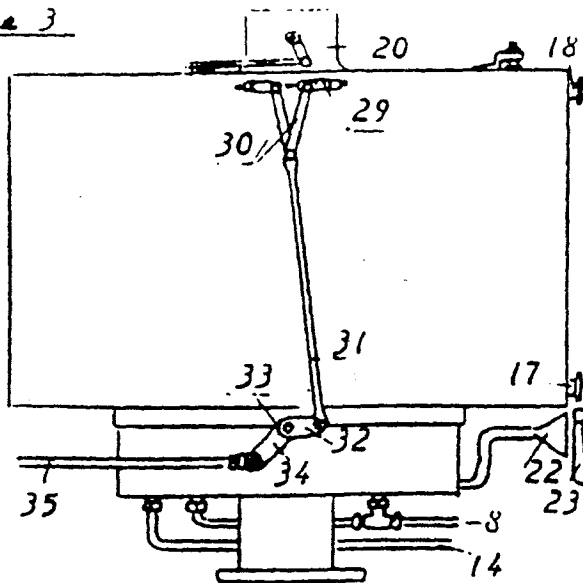

Figure 5

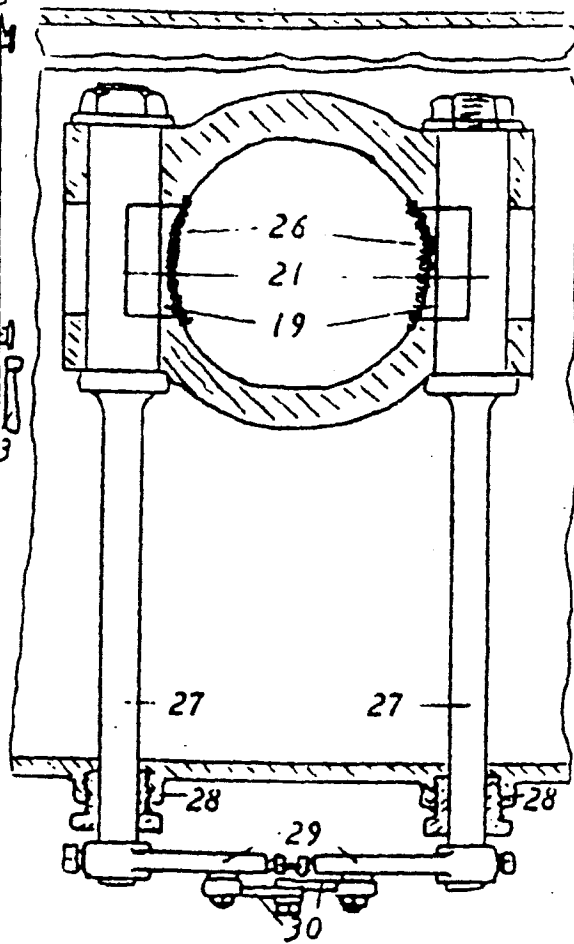

Figure 4

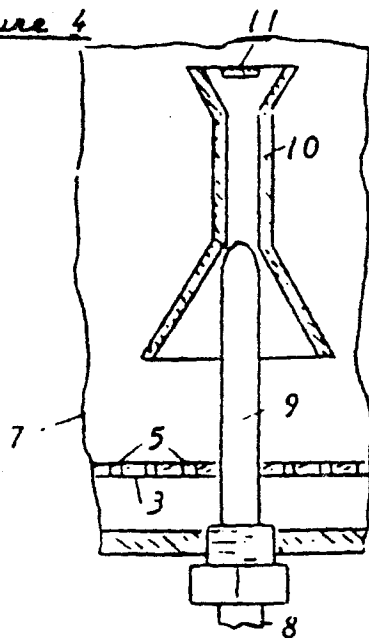

Figure 7

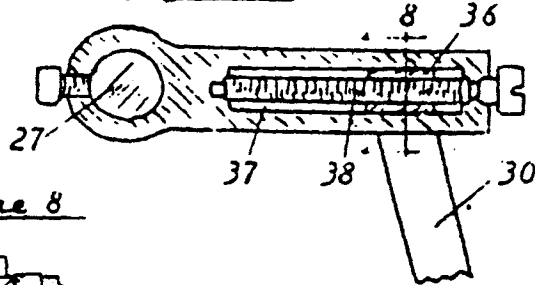

Figure 8

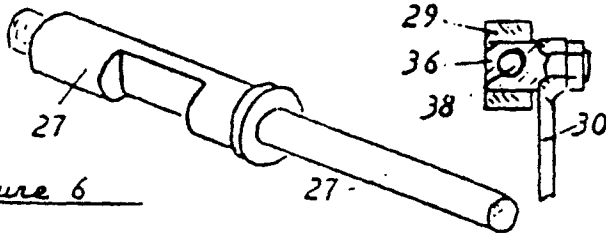
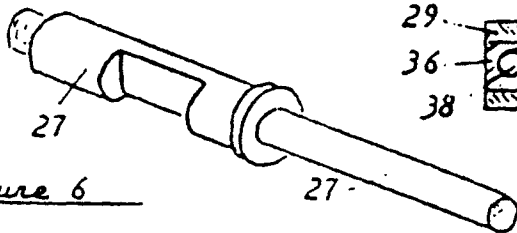

Figure 6



Carburetor

353538

Ottawa, January 3rd

1935

INVENTOR

Charles N. Pogue

by
E. Bowling
ATTORNEY

Jan 95
664

In the drawings, Fig. 1 is a vertical cross-sectional view through a carburetor embodying my invention. Fig. 2 is a horizontal sectional view through the main vaporizing or atomizing chamber, the same being taken on line 2-2 of Fig. 1. Fig. 3 is a side elevation of the carburetor, Fig. 4 is a detail sectional view of one of the atomizing nozzles and its associated parts. Fig. 5 is a detail cross-sectional view showing the means for controlling the passage of gases from the vapor expanding chamber into the intake manifold of the engine. Fig. 6 is a perspective view of one of the valves shown in Fig. 5. Fig. 7 is a cross-sectional view showing means for adjusting the valves shown in Fig. 5 and Fig. 8 is a cross-sectional view on line 8-8 of Fig. 7...

Referring now to the drawings, the numeral 1 indicates a main vaporizing and atomizing chamber for the liquid fuel located at the bottom of and communicating with a vapor heating and expanding chamber (2).

The vaporizing chamber is provided with a perforated false bottom (3) and is normally filled with liquid fuel to level X. Atmospheric air from a conduit (4) enters the space below the false bottom (3) and passes upwardly through perforations (5) in said bottom and then bubbles up through liquid fuel vaporizing a portion of it.

Liquid fuel for maintaining the level X in the chamber (1) passes from a usual fuel tank (not shown) through a pipe (6), and is forced by a pump (7) through a pipe (8) into and through a pair of nozzles (9) having their outlets located in the chamber (1), just above the level of the liquid fuel therein. The pump (7) may be of any approved form but is preferably of the diaphragm type, as is normally standard on most automobiles.

The nozzles (9) are externally threaded at their lower ends to facilitate their assembly into the chamber (1) and to permit them to be removed readily should cleaning be required. The upper ends of the nozzles (9) are surrounded by venturi tubes (10) having a baffle plate (11) located at their upper ends opposite the outlets of the nozzles. The liquid fuel being forced from the ends of the nozzles (9) into the restricted portions of the venturi tubes causes a rapid circulation of the air and vapors in the chamber through the tubes (10) and brings the air and vapors into intimate contact with the liquid fuel, with the result that a portion thereof is vaporized. Unvaporized portions of the liquid fuel strikes the baffles (11) and are thereby further broken up and deflected downwardly into the upwardly flowing current of air and

vapors.

The pump (7) is regulated to supply a greater amount of liquid fuel to the nozzles (9) than will be vaporized. The excess over that vaporized will drop into the chamber (1) and cause the liquid to be maintained at the indicated level. When the liquid fuel rises above the level, a float valve (12) will be lifted and the excess will flow through an overflow pipe (13) into a pipe (14) leading back to the pipe (6) on the intake side of the pump (7).

Such an arrangement permits large amounts of liquid fuel to be circulated by the pump (7) without more fuel being drawn from the tank than is actually vaporized and consumed in the engine. As the float valve (12) will set upon the end of the outlet pipe (13) as soon as the liquid level drops below the indicated level, there is no danger of vapors passing into the pipe (14) and hence into the pump (7) to interfere with its normal operation.

The upper end of the vaporizing chamber (1) is open and vapors formed by the atmospheric air bubbling up through the liquid fuel in the bottom of the chamber and those formed as the result of the atomization at the nozzles (9) will pass into the heating and expanding chamber (2). As is clearly shown in fig. 1, the chamber (2) comprises a series of tortuous passages (15) and (16) leading from the bottom to the top. The vapors pass through the passages (15) and the hot exhaust gases pass through the passages (16), a suitable entrance (17) and exit (18) being provided for that purpose.

The vapors passing upwardly in a zig zag path through the passages (15) will be brought into heat interchange relation with the hot walls of the passages (16) for the exhaust gases. The total length of the passages (15) and (16) is such that a relatively large reserve supply of the dry vapor is always maintained in the chamber (2), and by maintaining the vapors in heat exchange with the hot exhaust gases for substantial period, the vapors will absorb sufficient heat from those gases to cause the vapors to expand, with the result that when they are withdrawn from the top of the chamber (2) they will be in a truly vapor phase, and due to their expansion, relatively light.

Any minute droplets of liquid fuel entrained by the vapors in the chamber (1) will precipitate out in the lower passages (15) and flow back into the chamber (1) or else be vaporized by the heat absorbed from the hot exhaust gases in their passage through chamber (2).

The upper end of the vapor passages (15) communicates with openings (19) adjacent the upper end of the downdraft tube (20) leading to the intake manifold of the engine. Valves (21) are interposed in the openings (19) so that the passages of the vapors therethrough into the air tube may be controlled. The valves (21) preferably are of the rotary plug type and are controlled as hereinafter described.

Suitable means are provided for causing the vapors to be maintained in the chamber (2) under a pressure greater than atmospheric, so that when the valves (21) are opened the vapors will be forced into the air tube (20) independently of the suction of the engine. Such means may comprise an air pump for forcing the atmospheric air through the pipe (4) into the chamber (1) beneath the false bottom (3), but I prefer merely to provide the pipe (4) with a funnel shaped inlet end (22) and located just behind the usual fan (23) equipped on most all automobiles. That will cause the air to pass through the pipe (4) with sufficient force to maintain the desired pressure in the chamber (2) and the air being drawn through the radiator by the fan will be preheated prior to its introduction to the chamber (1) and hence will vaporize greater amounts of the liquid fuel. If desired, the pipe (4) may be surrounded by an electric or other heater, or exhaust gases from the engine may be passed around it to further preheat the air passing there through prior to its introduction into the liquid fuel at the bottom of the chamber (1). The air tube (20) is provided with a butterfly valve (24) for throttle, and a choke valve (25) as is customary with carburetors used for internal combustion engines. The upper end of the air tube (20) extends above the chamber (2) a distance sufficient to receive an air filter and / or silencer, if desired.

A low speed or idling jet (25) has its upper end communication with the passage through the air tube (20) adjacent the throttling valve (24) and its lower end extending into the liquid fuel in the bottom of the chamber (1).

A low speed jet will supply fuel to the engine when the valves are in a position such as to close to passage (19). However, the passage through the idling jet (25) is so small that under normal operations the suction thereon is not sufficient to lift the liquid fuel from the bottom of the chamber (1).

To prevent the engine from backfiring into the vapor chamber (2) the ends of the passages (19) are covered

with a fine mesh screen (26) which operates on the principal of a miners lamp, and will prevent the vapors in the chamber (2) from exploding in the event of a backfire, but will not interfere substantially with the passage of the vapors from the chamber (2) into the air tube (20) when the valves (21) are in the open position. The air tube (20) preferably is in the form of a venturi with the greatest restriction being at that point where the openings (19) are located, so that when the valves (21) are opened there will be a pulling force on the vapors because of the increased velocity of the air at the restricted portion of the air tube (20) opposite the openings (19) as well as an expelling force on them due to the pressure in the chamber (2).

As shown in fig. 3, the operating mechanism for the valves (19) is so connected to the operating mechanism for the throttle valve (24) that they are opened and closed simultaneously with the opening and closing of the throttle valve, so that the amount of vapor supplied to the engine will at all times be in proportion to the demands placed on the engine. To that end, each valve (19) has an extension or operating stem (27) protruding through one of the side walls of the vapor heating and expanding chamber (2). Seals or packing glands (28) of the ordinary construction surround the stems (27) where they pass through the chamber wall to prevent leakage of vapors at those points.

Operating arms (29) are rigidly secured to the outer ends of the stems (27) and extend toward each other. The arms are pivotally and adjustably connected to a pair of links (30) which at their lower ends are pivotally connected to an operating link (31) which in turn is pivotally connected to an arm (32) rigidly secured on an outer extension (33) of the stem of the throttle valve which is connected to an operating link (35) leading from the means for accelerating the engine.

The means for adjustably connecting the upper ends of the links (30) to the valve stems (27) of the valves (19) so that the amount of vapors delivered from the chamber (2) may be regulated to cause the most efficient operation of the particular engine to which the carburetor is attached, comprise angular slides (36) to which the upper ends of the links (30) are fastened, and which are slidable but not-rotatably mounted in guideways (37) in the arms (29). The slides (36) have threaded bones through which screws (38) pass. The screws are rotatably mounted in the arms (29), but are held against

longitudinal movement so that when they are rotated the slides (36) will be caused to move along the guidways (37) and change the relative position of the links (30) to the valve stems (27) so that a greater or less movement, and consequently a greater or lesser opening of the ports (19) will take place when the throttle valve (24) is operated.

For safety and for most efficient operation of the engine, the vapors in the chamber (2) should not be heated or expanded beyond a predetermined amount and in order to control the extent to which the vapors are heated and consequently the extent to which they are expanded, a valve (39) is located in the exhaust passage (16) adjacent to the inlet (17). The valve (39) is preferably thermostatically controlled, as for example, by an expanding rod thermostat (40) which extends through the chamber (2). However, any other means may be provided for reducing the amount of hot exhaust gases entering the passages (16) when the temperature of the vapors in the chamber reaches or exceeds the optimum.

The engine has been described in detail in connection with a down-draft type of carburetor, but it is to be understood that its usefulness is not restricted to that particular type of carburetor, but could be made adaptable to the side-draft or even the updraft type of carburetor if desired, and that the manner in which the mixture of atmospheric air and dry vapors is introduced into the engine cylinders is immaterial as far as the advantages of the engine are concerned.

The term "dry vapor" is used herein to define the physical condition of the liquid fuel vapor after the removal of all liquid droplets or mist which is frequently entrained in what is ordinarily termed a vapor.

From the foregoing description, it will be seen that the present invention provides a carburetor in which the breaking up of the liquid fuel, or total vaporization, for subsequent use in the engine is totally independent of the suction created by the engine, and that after the liquid fuel is broken up and totally vaporized it is maintained under a slight pressure in a heated space for length of time sufficient to permit all entrained liquid or mist particles to be separated or vaporized and to permit the dry vapors to expand prior to their introduction and admixture with the main volume of atmospheric air passing into the engine cylinders.

Charles N. Pogue
Inventor

347 College Avenue, Winnipeg, Manitoba
August 10th, 1936

To Whom it May Concern:

I have today had the pleasure to make a test of the Pogue Carburetor. Same was installed in a Ford V-6 Coupe, 1934 model. I have taken extra precautions to turn off the speedometer to null on the trip mileage.

I drove the car twenty-eight miles on one pint of gasoline. I tested the car for speed up to seventy-five miles per hour and as low as three miles per hour; and the car performed exceptionally nicely. In fact, I can say the performance was all anyone could desire in every shape or form.

Yours truly,
(signed) S. Stockhammer

Does this device of Mr. Pogue's really work? We don't know, as we are a research company only (we research and find things and information). We have not taken the time or money to physically and mechanically research the device any further than to find the information you have read here. We did talk to one young man in Salt Lake City though, who claims he made one such device (with Mr. Pogue's information and drawings) for a small lawn mower engine, and that the engine ran 24 hours a day for a week on one quart of gasoline. That is pretty good we think, most lawn mowers run out a pint of gas in 4 to six hours.

Patents are only good for a given number of years, depending on the item and are not renewable. Since Mr. Pogue's patent has, long since, run out, you are welcome to use it or any part of it as you see fit. We are sorry that the drawings do not include any dimensions, but this is how they were submitted for patent application - and we have been unable to find any...

If you plan to produce one of these devices - Good luck and we hope you are successful, and we would like to hear from you on your results. Also, about his device. (fact or rumor)

Best Regards
Allan Wallace

Newsletters/Periodicals

NEW SCIENCE/TECHNOLOGY/FREE ENERGY

Electric Spacecraft Journal. Published quarterly, annual subscription rate \$24, Canada/Mexico \$29, other countries \$39. ESJ publishes research articles on new science, inventions and network notes from the ESJ network of individuals sharing ideas about these topics. Devoted especially to discovering the means/mechanisms for "electric" spacecraft and all that such understanding would mean for our civilization. I have known the editor Charles A. Yost the last few years and he spoke at our 1995 symposium. I find Charles' ESJ to be interesting and informative, and although most articles are very technical there are aspects of the journal that the average reader should find comprehensible and of interest. Charles A. Yost editor. ESJ, 73 Sunlight Drive, Leicester, North Carolina 28748. Phone 704-683-0313 Fax 683-3511.

The Space Energy Journal Published Quarterly. \$35 U.S., \$40 Canada & Mexico, \$50 elsewhere. Jim Kettner and Don Kelly editors. This journal publishes the positive and the negative results of testings of free energy machines and other new science experiments. The discussion of new science ideas is technical and yet also very down to earth so that the average reader should follow most of it. I have met Don Kelly through my association with the International. Assoc. for New Science/ International. Symposiums for New Energy and he is familiar with the Russell work too. Space Energy Association, P.O. Box 11422, Clearwater FL 34616. Phone/Fax 813-461-7119.

New Energy News is the newsletter from the Institute for New Energy. It is a collection of reports on inventions, ideas and of publications relating to alternate and free energy. Monthly free to members with member fee of \$35 and \$60/yr. to corporations, libraries and universities. Hal Fox Editor, P.O. Box 58639, Salt Lake City, UT 84158-8639. Phone 801-583-6232 Fax 583-2963.

The *Planetary Association for Clean Energy* newsletter publishes articles to facilitate the development of a wide range of clean energy technologies including free energy technologies. Usually quarterly \$35/yr. Canada, \$40 USA, \$45 elsewhere. Andrew Michrowski, editor, Planetary Assoc. for Clean Energy, Inc. 100 Bronson Ave. Suite 1001, Ottawa, Ontario, Canada K1R 6G8. Phone 613-236-6265 Fax 235-5876.

INVESTMENT/INTL. POLITICS/ ETC.

The Reaper. 36 issues per publishing year. I year- \$195. 10 issue trial - \$60. *The Reaper* is a no holds barred newsletter examining our current global and national economic/political status with an eye towards assisting investors in commodities, currencies, real estate, etc., etc. Publisher R.E. McMaster Jr. is an acquaintance of mine who I introduced to the Russell's work and I have subscribed to his NL off and on over many years - not because I am an investor (I should be and if I would have followed much of his advice would have made some cash, but I'm too involved in other work), but because I have been fascinated with R.E.'s analysis of our world situation. Called the Indiana Jones of the Christian economists by some he has a 'Christian' point of view but it is not conventional in my estimation. He is aware of new energy and natural health/healing practices and reports on these areas at times. P.O. Box 84901, Phoenix, AZ 85071. Phone 800-528-0559.

EARTH CHANGES/ESOTERIC

The Earth Changes Report 12 issues/yr. \$36; Canada, Mexico, Alaska & Hawaii \$46/yr.; \$56/yr. elsewhere. Published by futurist/psychic predictor Gordon Michael Scallion gives Gordon's psychic predictions and a review of his hits and misses as well as articles in the new age spiritual genre and a report of earthquake, climate changes, etc. worldwide. I have watched Gordon Michael's predictions for the last several years and while he is not 100% on target he has been close enough on enough times to be much more than just coincidence. Published in the spirit of better to be prepared for what does or does not happen than to be unprepared for what does happen, the ECR is a good monthly review of earth changes as they happen and of what might happen beyond most folks wildest dreams - both pro and con. Matrix Institute, P.O. Box 336, Chesterfield, NH 03443. Phone 1-800-628-7493.

ESOTERIC/NEW SCIENCE

New Science News

published by the International Association for New Science (IANS) addresses metaphysical and esoteric perspectives on pro-social topics such as sociopolitical, new age, and new science concepts. I have spoken at several of their conferences on the Russell's work as well as alternative healing topics. Quarterly, \$35 membership. Bear Jack Gebhardt, editor, IANS, 1304 South College Ave., Ft. Collins, CO 80524

In The Wave Lies The Secret Of Creation

by Dr. Timothy A Binder

This soft cover treatise on the Russell Cosmogony with 44 color charts, 10 black & white charts and 31 diagrams is now available. The book presents a Universal Systems Model that is applied to language in order to facilitate greater comprehension of the Russell Cosmogony. A comparison of Russellian Science and the Science of his time is given as is a description of the chief elements of the Cosmogony including: the eighteen dimensions, formula of the locked potentials, wave mechanics, the cube and the sphere, periodic charts, thermodynamic laws, and Newton's first and third laws versus the Russell Cosmogony to give a firm basis to understand Walter Russell's scientific paintings and charts.

An analysis of the paintings and charts comprises the second half of the book. Most of the paintings included in this volume have never before been published. The cover of this issue of *Fulcrum* has one of these paintings as its front cover piece.

Cost is \$35 plus \$3 postage within the USA. Phone 1-800- 882- LOVE to order your copy today!

Subscription and Back Issues Information

An annual subscription to *Fulcrum* published 3 times a year is \$25 postpaid in the USA \$30 Canada and \$35 elsewhere. Back issues are available at \$7 an issue.

READERS,

We will send a sample copy of any issue of the FULCRUM to interested individuals who are not subscriber; simply mail us the name, address and number of the issue you would like us to share. Now is the time for God's science of creation to move into human consciousness. Thanks for your support!

Name: _____

Street: _____

City, State, Zip: _____

Phone: _____

Enclosed for FULCRUM:

_____ Back Issues @ \$7 each - Vol. #(s) _____ • _____ 1 year (3 issues) \$25

Send to: FULCRUM, Science Journal
University of Science & Philosophy
P.O. Box 520, Wyanesboro, VA 22980
Phone #: (540) 942-5161 Fax: (540) 942-8705 Orders: (800) 882-LOVE